

# ASSEMBLY INSTRUCTION FOR ACME FURNITURE

## MODEL# OF00015/OF00016

Thank you for purchasing the quality product. Be sure to check all packing material carefully for small parts which may have come loose inside the carton during shipment. Separate, identify and count all parts and metal hardware. Compare with all parts list to be sure all parts are present. If any part(s) are missing or damaged, please contact your local furniture dealer. For efficient and speedy service, please indicate the model number and code letter of part(s) needed.

**\*\*\*Do not fully tighten screws until fully assembled\*\*\***

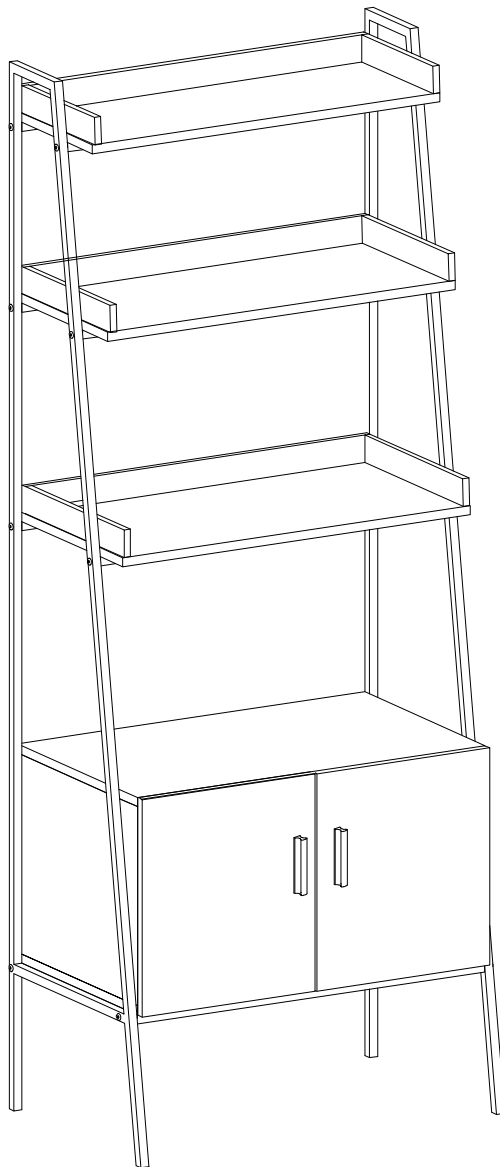

### Attention:

**\*\*\*Some number parts listed on the instruction sheet may not be in parts bag as they may already be assembled. Carefully check parts and packing materials prior to ordering replacements.**

# General Assembly Guidelines

- I. Ensure that all parts and hardware are available before beginning assembly.
- II. Follow each step carefully to ensure the proper assembly of this product.
- III. Two people are recommended for ease in the assembly of this product.
- IV. The three main types of hardware used to assemble this product are: wood dowels, screws and bolts.
- V. The provided glue is to secure wood dowels in place. When first inserting dowels, locate the appropriate hole for the dowel, place a small amount of glue in the hole and insert the dowel. Wipe away excess glue immediately.

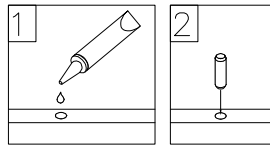

In future assembly steps when dowels are necessary to attach assembly parts together, place a small amount of glue on the end of the dowel before attaching parts together. Wipe away excess glue immediately.

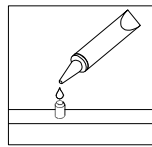

- VI. A Phillips head screwdriver is required for the assembly of this product.

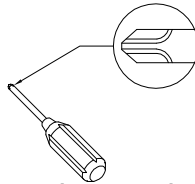

- VII. Power tools should not be used to assemble this product.

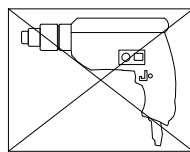

- VIII. Drill may be needed for securing product to wall.

- IX. Concealed hinges are three-way adjustable.

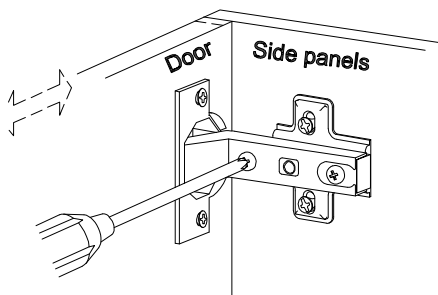

Horizontal  
by screw adjustment

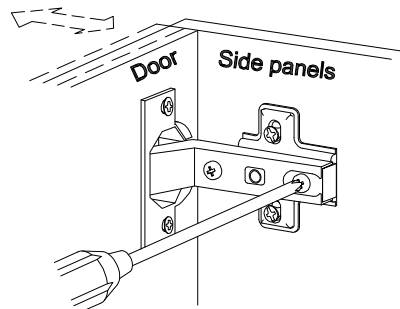

In-and-Out  
by loosening the hinge-arm  
mounting screw or via cam

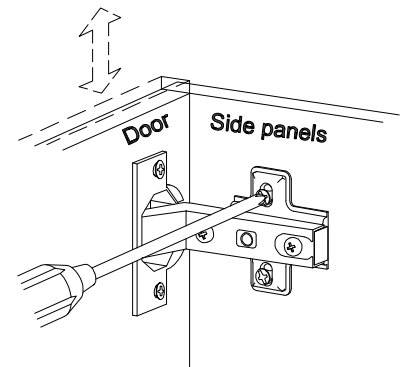





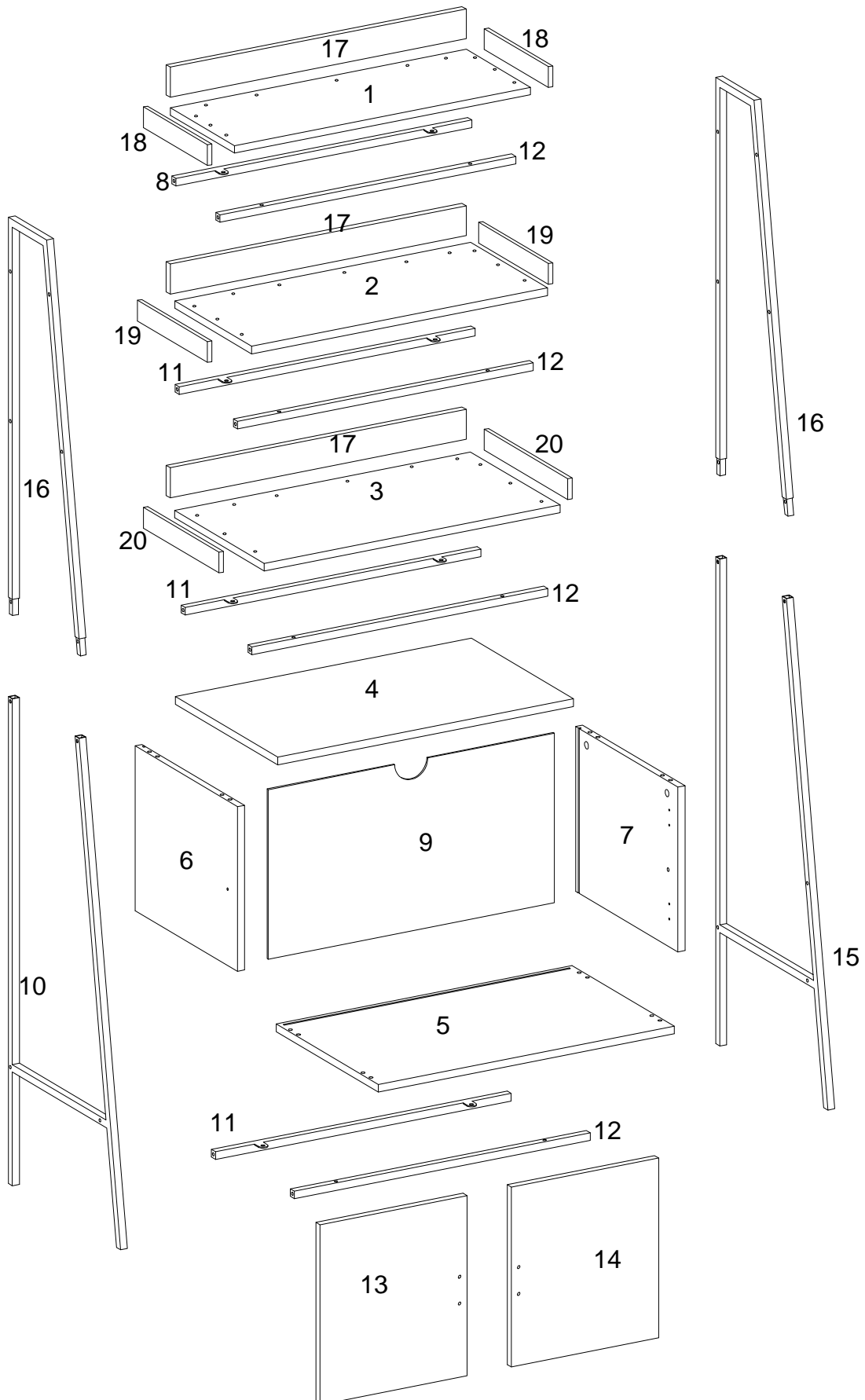















Vertical  
Via slots in the mounting  
plate or via cam adjustment



# Parts List



# Hardware List



A		Ø1/4"x12mm	Bolt	9 pcs	O		Plastic wedge	4 pcs
B		Ø1/4"x25mm	Bolt	24 pcs	P		Plate	2 pcs
C		M4mm	Hex Key	1 pcs	Q		Glue tube	1 pcs
D		Ø16x6.5x1.0mm	Washer	1 pcs	R		Ø1/4"x20mm Bolt	2 pcs
E		40x25x20mm	Bracket	1 pcs	S		Hinge	4 pcs
F		Ø4x30mm	Screw	1 pcs	T		Handle	2 pcs
G			Wall anchor	1 pcs	U		Ø4x18mm Screw	4 pcs
H		Ø6x50mm	Screw	4 pcs	V		Ø4x40mm Screw	27 pcs
I		Ø8x30mm	Wooden dowel	20 pcs	W		Ø3.5x16mm Screw	16 pcs
J		Ø6x35mm	Cam lock	4 pcs				
K		Ø15x11mm	Cam bolt	4 pcs				
L			Sticker	4 pcs				
M		Ø3x17mm	Screw	4 pcs				
N		Ø4x12mm	Screw	4 pcs				

# Step 1

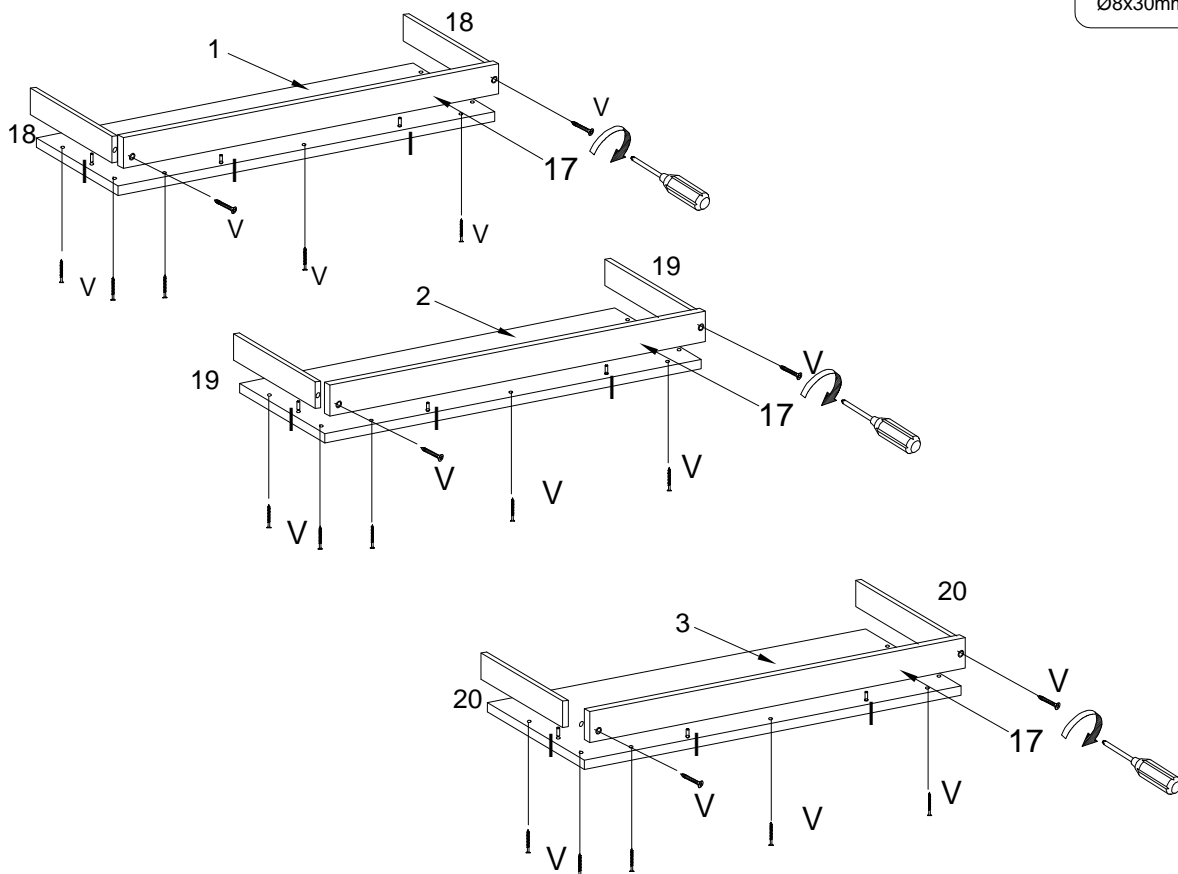
I x 12	V x 27
	
Ø8x30mm	Ø4x40mm



# Step 2

I x 8	J x 4
	
Ø8x30mm	Ø6X35mm

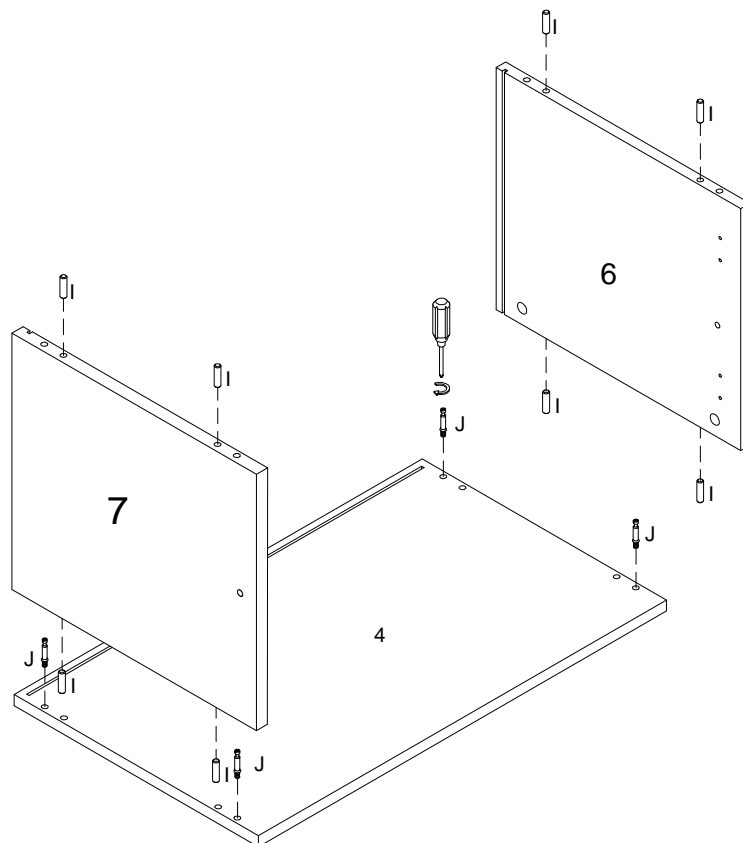

# Step 3

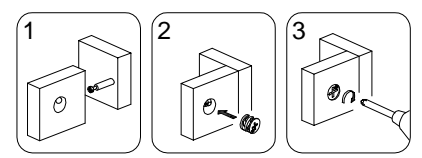
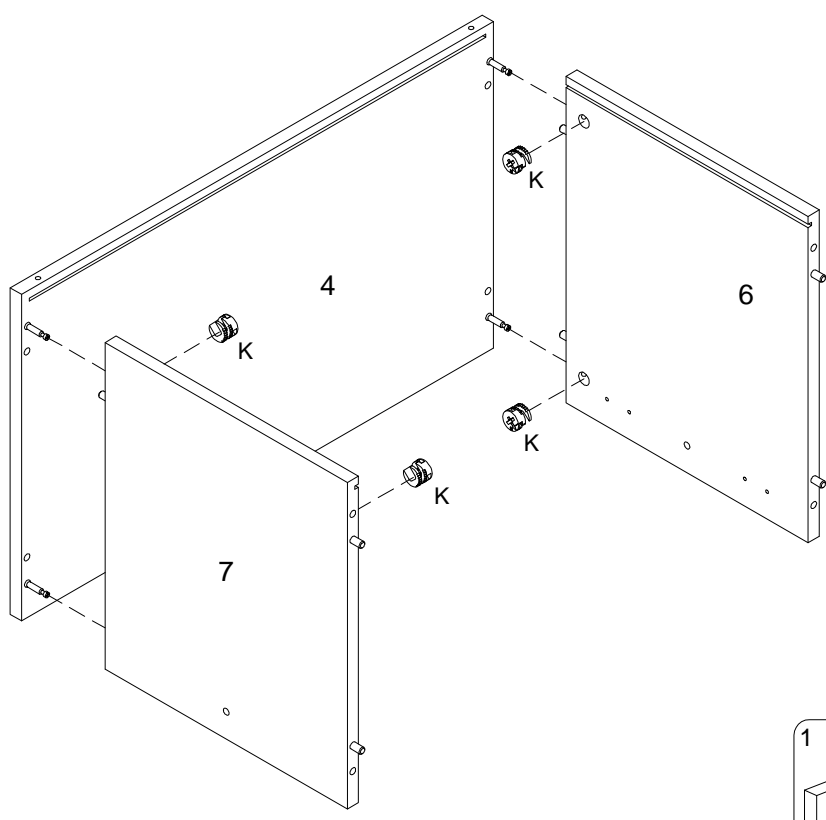

K x 4  
Ø15X11mm

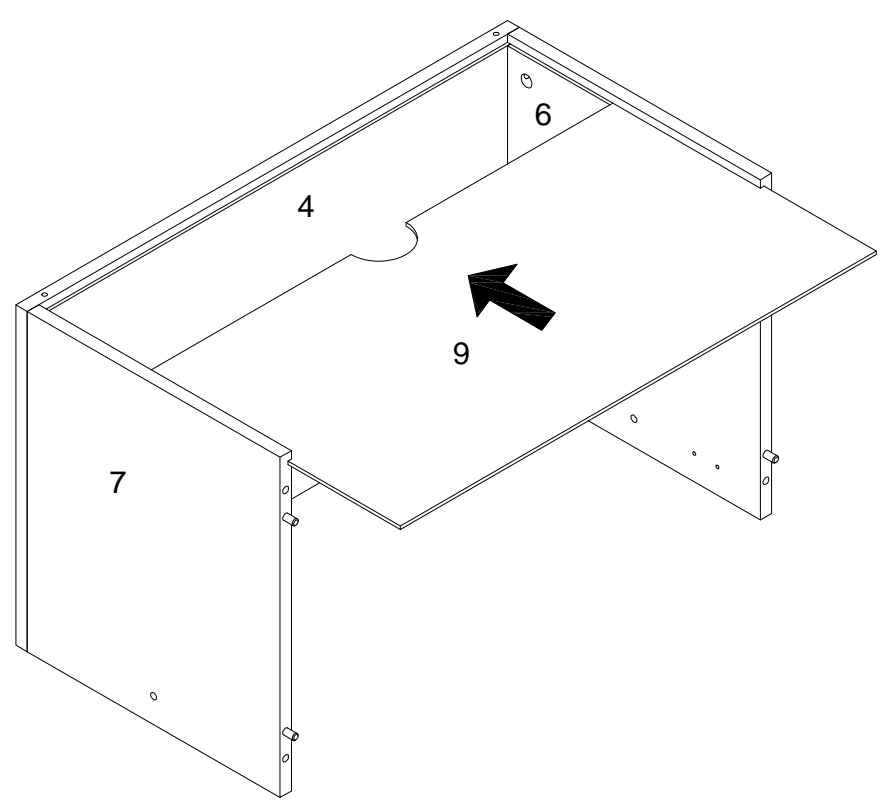

# Step 4



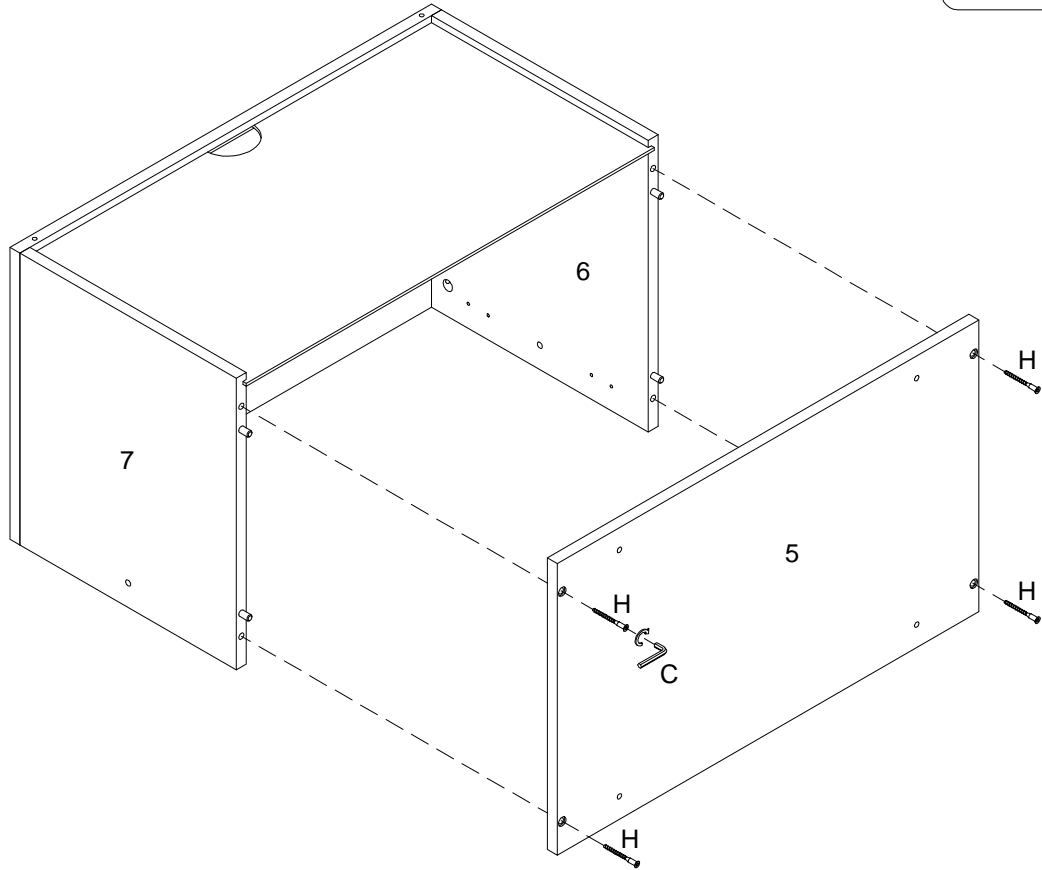

# Step 5

H x 4	C x 1
	
Ø6x50mm	M4mm



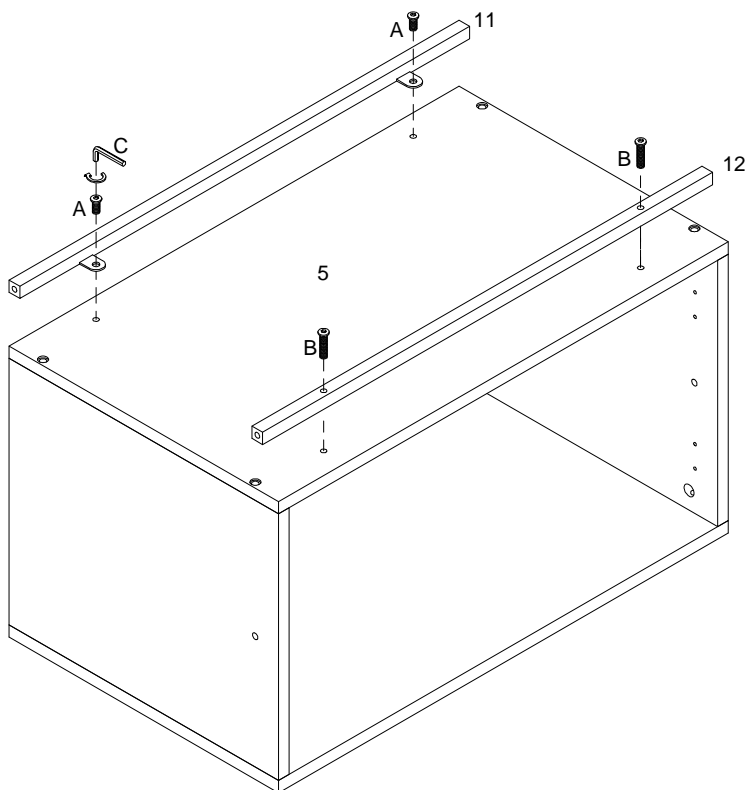

# Step 6

A x 2	B x 2	C x 1
		
Ø1/4"x12mm	Ø1/4"x25mm	M4mm



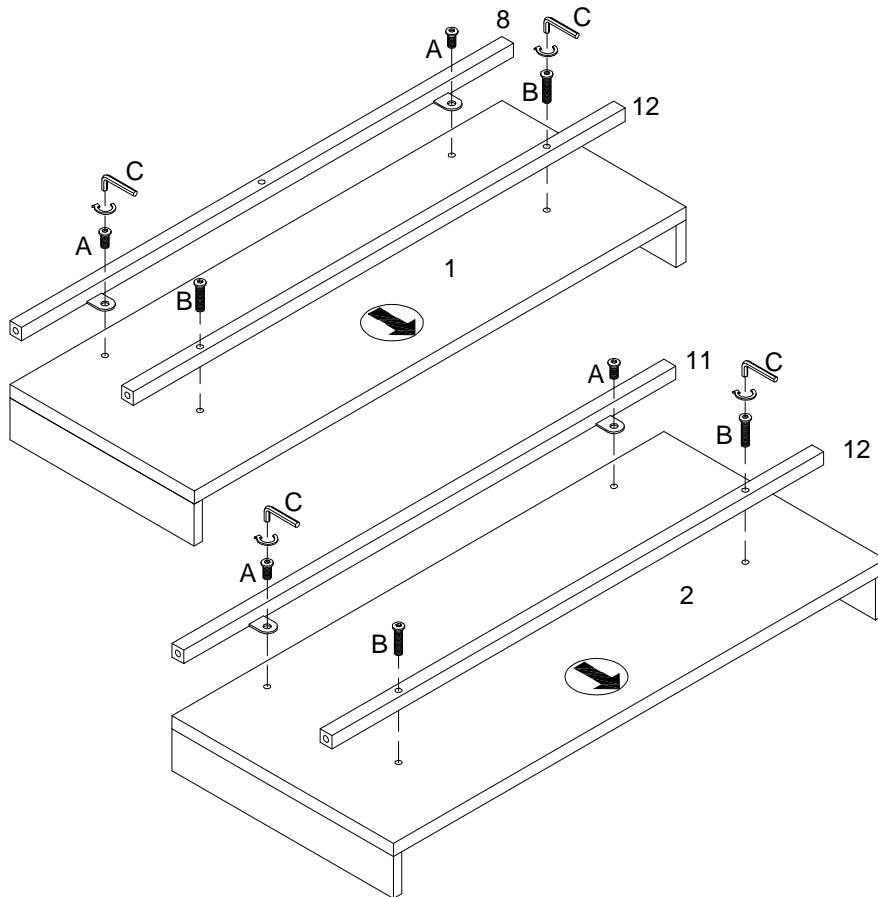

# Step 7

A x 4  Ø1/4"x12mm	B x 4  Ø1/4"x25mm	C x 1  M4mm
--	--	--



# Step 8

A x 2  Ø1/4"x12mm	B x 2  Ø1/4"x25mm	C x 1  M4mm
--	--	--

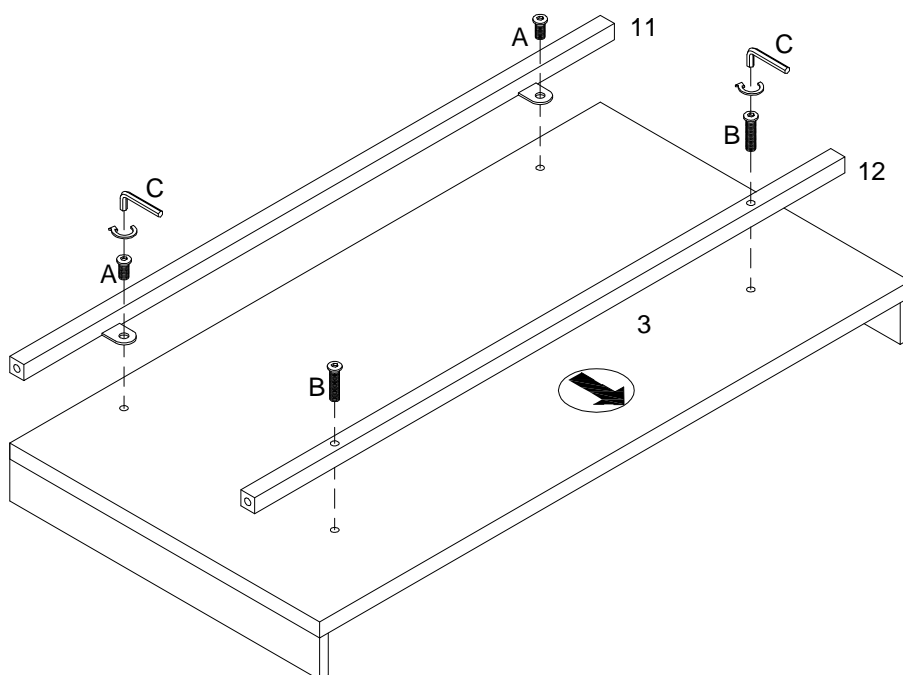



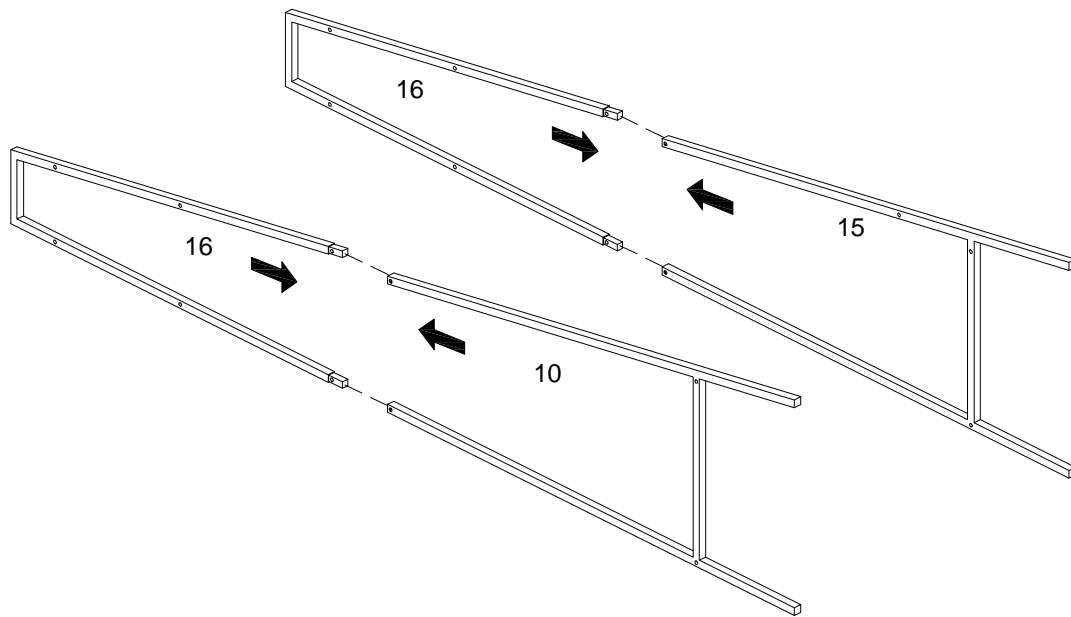

# Step 9



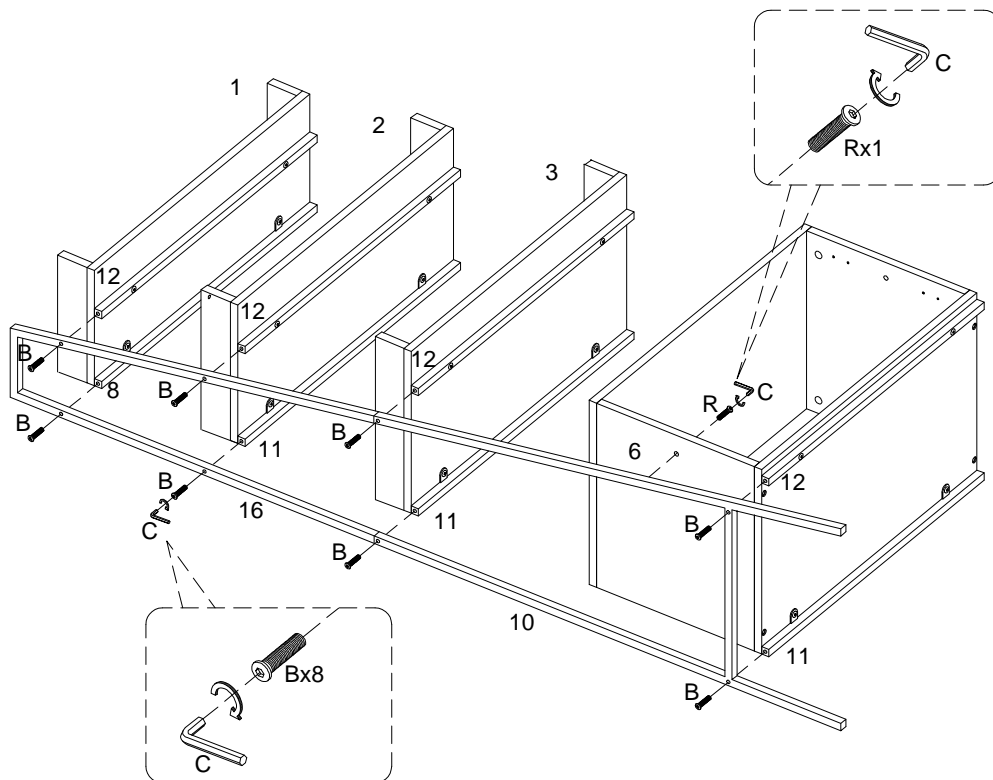

# Step 10

<b>B x 8</b>  Ø1/4"x25mm	<b>C x 1</b>  M4mm	<b>R x 1</b>  Ø1/4"x20mm
---	---	---



# Step 11

**B x 8**  
  
Ø1/4"x25mm

**C x 1**  
  
M4mm

**R x 1**  
  
Ø1/4"x20mm

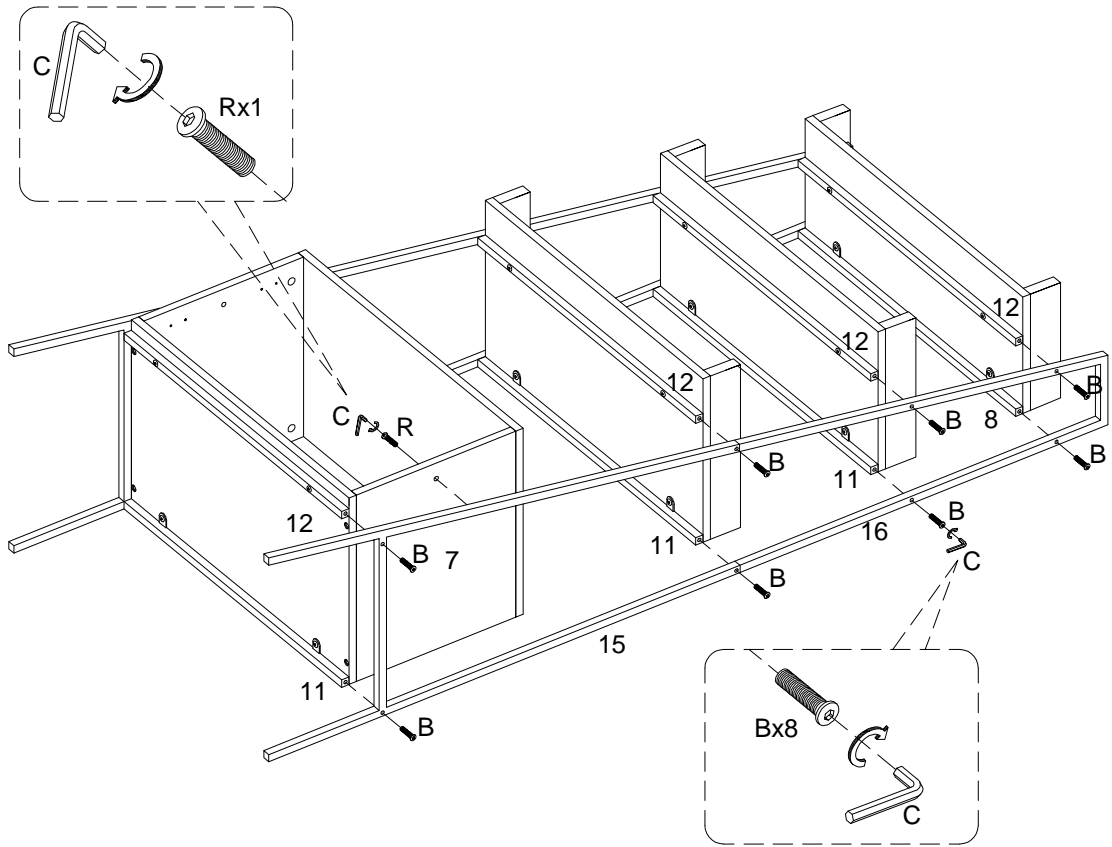

# Step 12

**L x 4**  

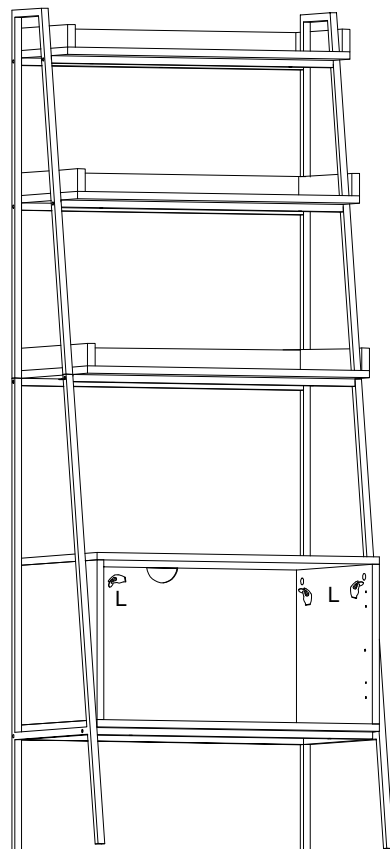

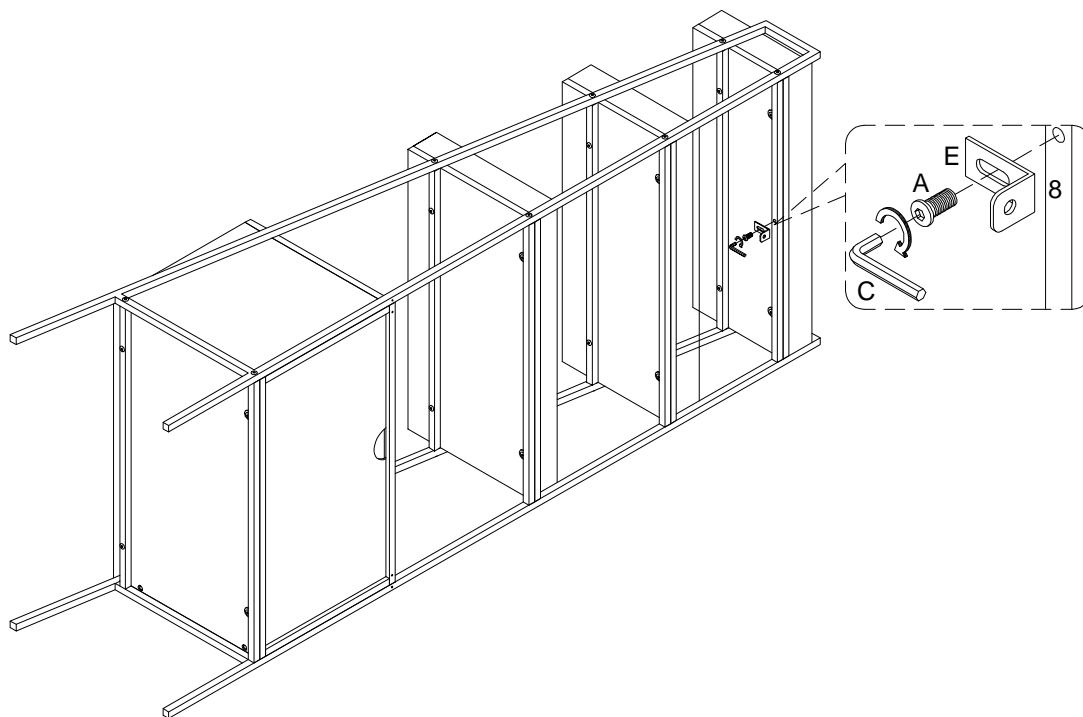
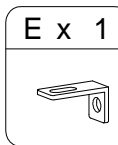
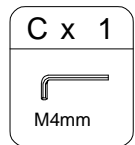
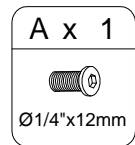

# Step 13

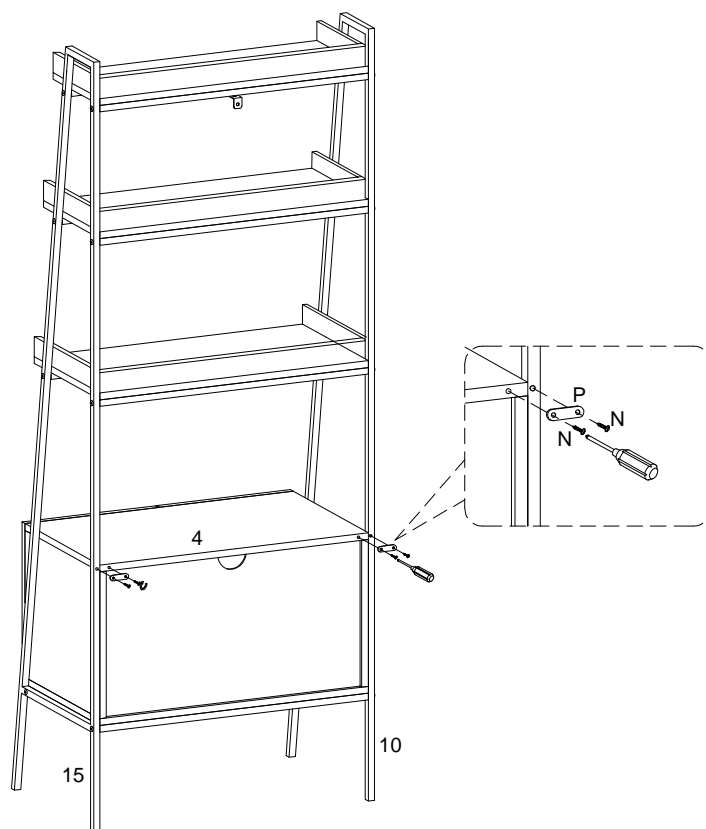
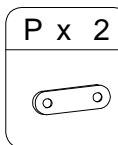
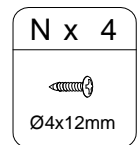

# Step 14





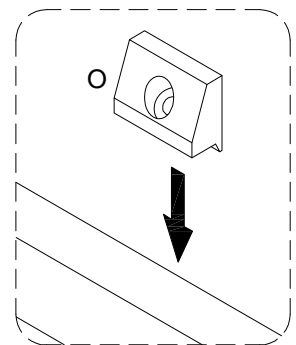
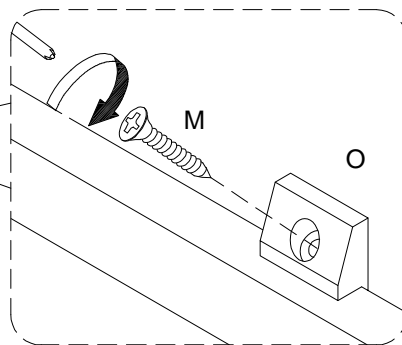
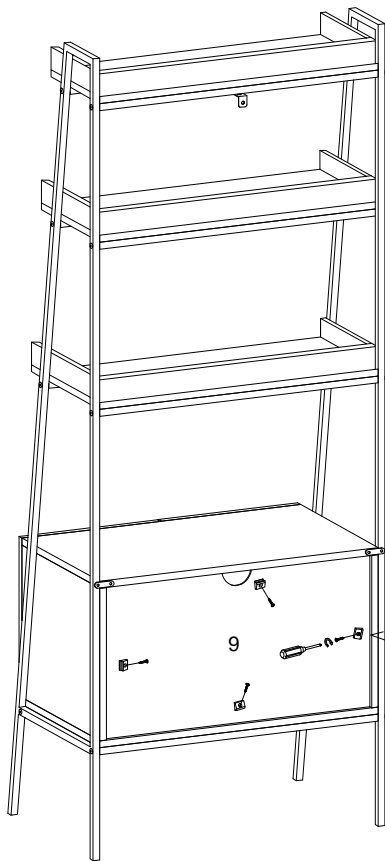

# Step 15

M x 4	O x 4
	
Ø3x17mm	



# Step 16

U x 4	W x 8	S x 4	T x 2
			
Ø4x18mm	Ø3.5x16mm		

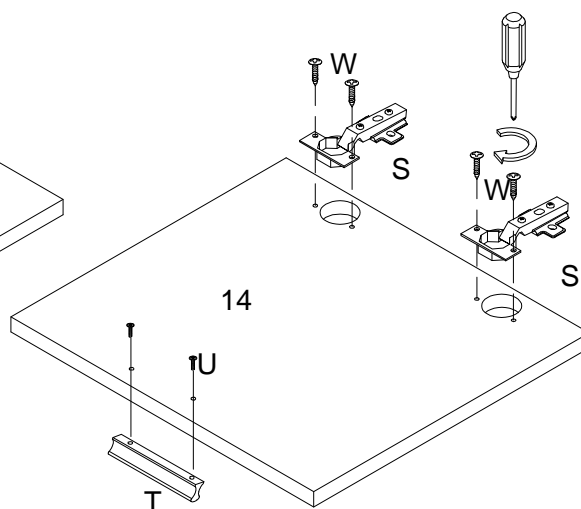
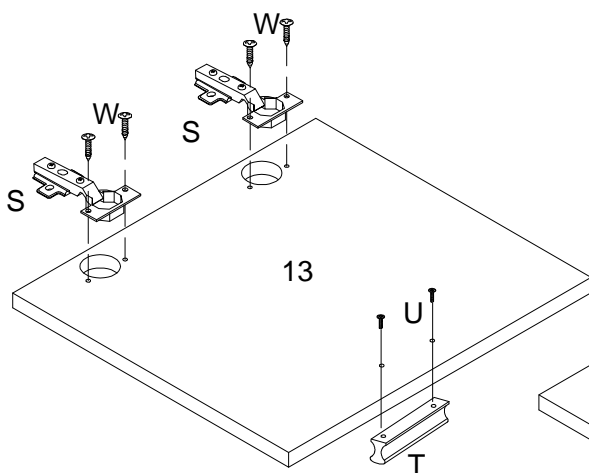

# Step 17

W x 4

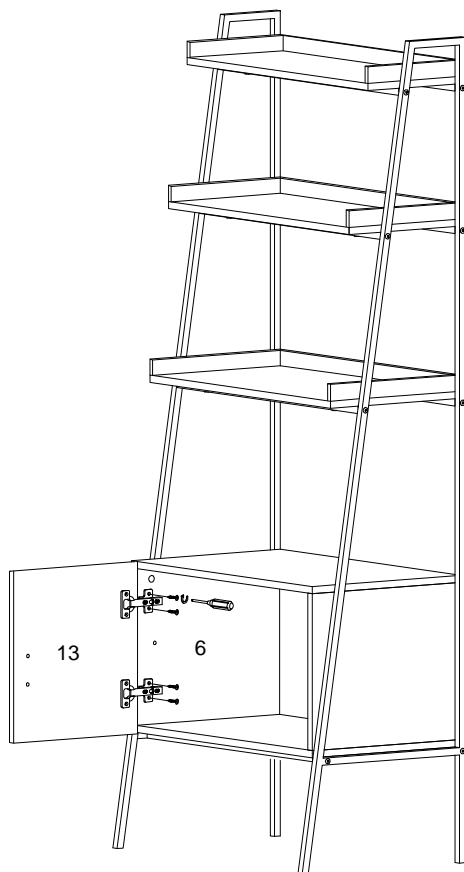
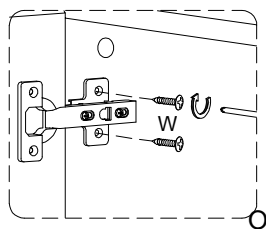
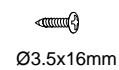

# Step 18

W x 4

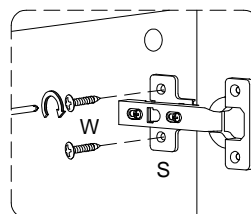
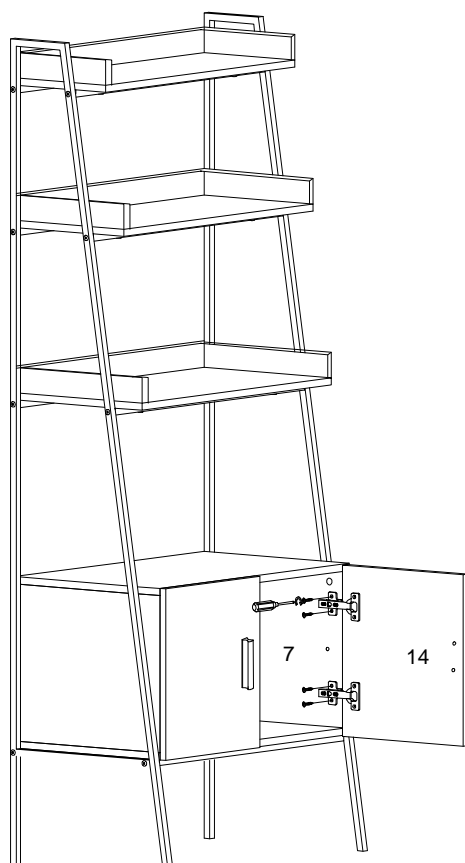
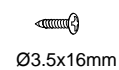

# Step 19

G x 1

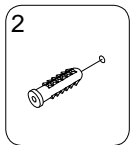
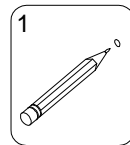
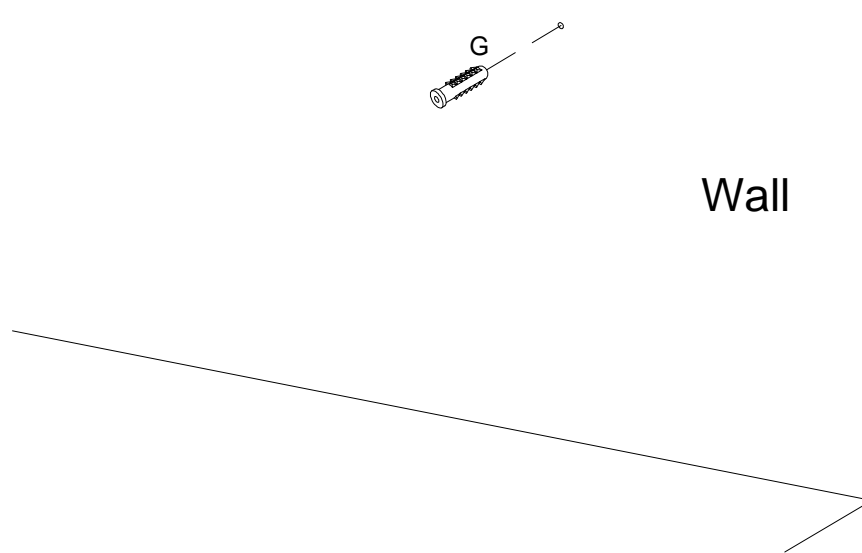

# Step 20

D x 1



Ø16x6.5x1.0mm

F x 1



Ø4x30mm

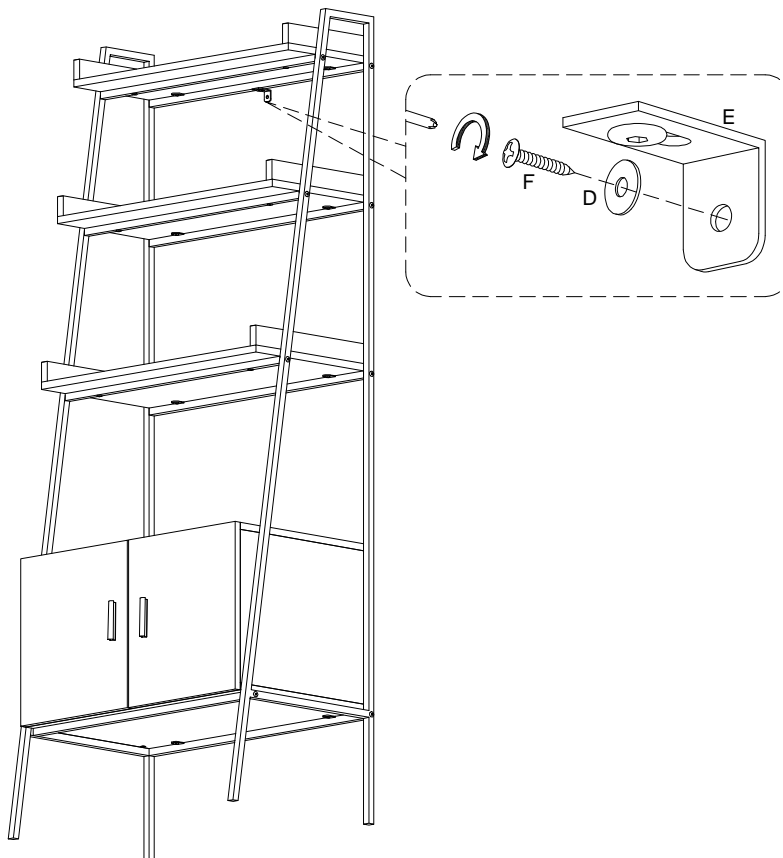

# Step 21

