

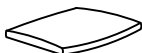



ASSEMBLY INSTRUCTION FOR ACME FURNITURE

MODEL# DN02926

Thank you for purchasing the quality product. Be sure to check all packing material carefully for small parts which may have come loose inside the carton during shipment. Separate, identify and count all parts and metal hardware. Compare with all parts list to be sure all parts are present. If any part(s) are missing or damaged, please contact your local furniture dealer. For efficient and speedy service, please indicate the model number and code letter of part(s) needed.

*****Do not fully tighten screws until fully assembled*****

COMPONENT PARTS			
DESCRIPTION	PART NAME		Q'TY(PCS)
①	CHAIR BACK		2
②	CHAIR SEAT		2
③	CHAIR LEG WITH LABEL "L"		2
④	CHAIR LEG WITH LABEL "R"		2
⑤	FRONT RAIL WITH LABEL " 5 "		2
⑥	BACK RAIL WITH LABEL " 6 "		2

HARDWARE REQUIRED

Ⓐ		BOLT	M6 X 30MM	12	PCS
Ⓑ		BOLT	M6 X 50MM	4	PCS
Ⓒ		BOLT	M6 X 60MM	8	PCS
Ⓓ		LOCK WASHER	M6 X 12MM	24	PCS
Ⓔ		WOOD DOWEL	M8 X 30MM	12	PCS
Ⓕ		BARREL NUT		8	PCS
Ⓖ		ALLEN KEY	M4 X 100MM	1	PCS
Ⓗ		PVC NUT		8	PCS
Ⓘ		WOOD BUTTON		8	PCS

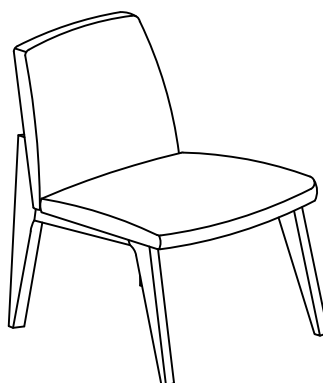

x 2

Attention

Some number parts listed on the instruction sheet may not be in parts bag as they may already be assembled. Carefully check parts and packing materials prior to ordering replacements.

How to assemble:

 Only tighten all bolts when all bolts aligned with bolt inserts.

STEP 1

NOTICE:
When assembling, follow the of the label .

STEP 1.1

STEP 1.2

STEP 1.3

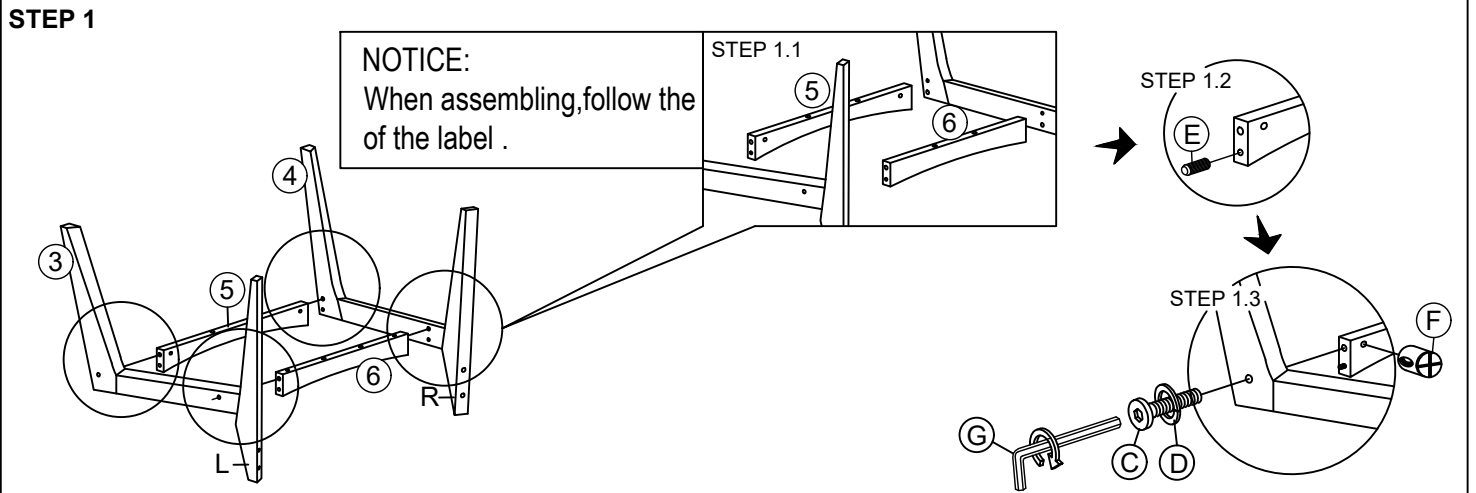

STEP 2

STEP 2.1

STEP 2.2

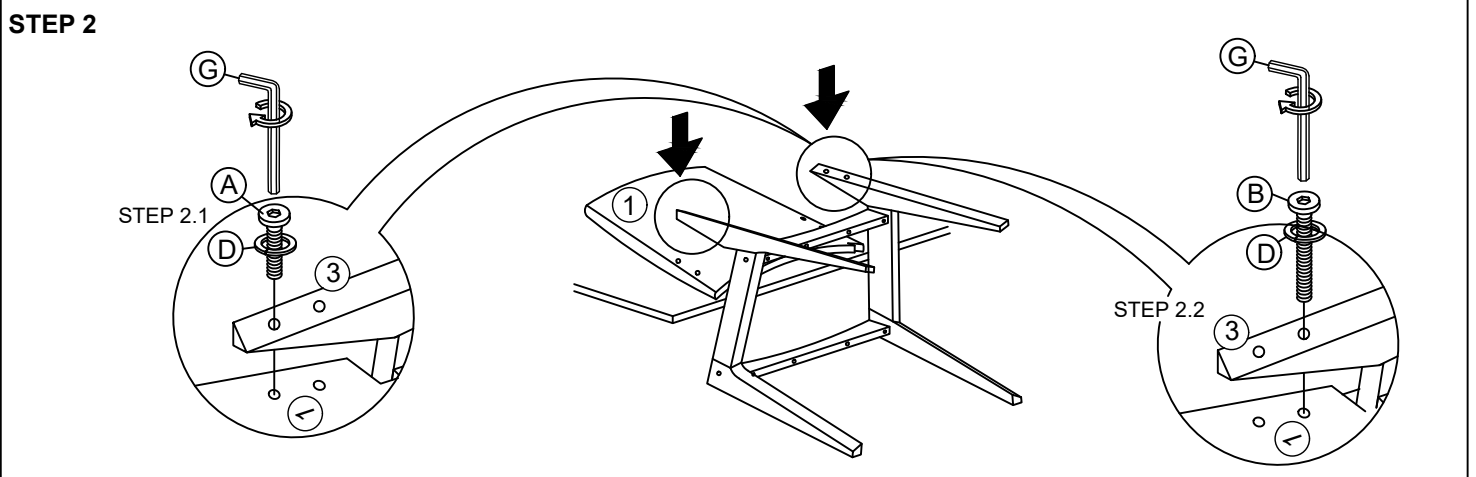

STEP 3

STEP 3.1

STEP 3.2

STEP 3.3

STEP 3.4

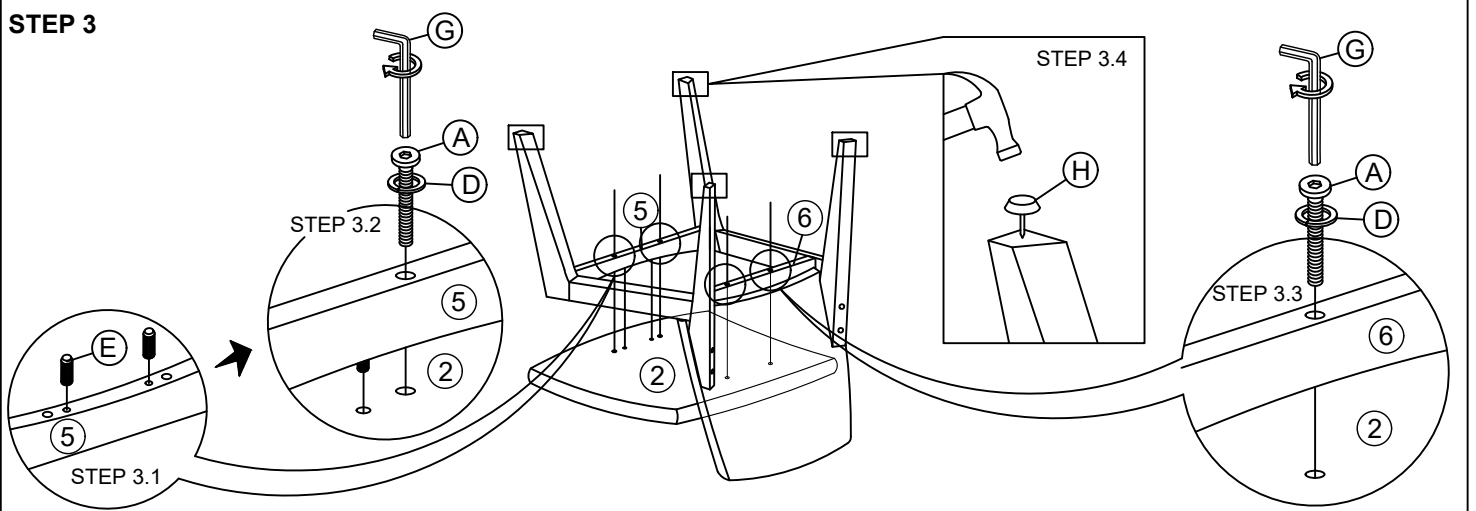

STEP 4

NOTICE:
Fully tighten screws before insert wood button (I).

