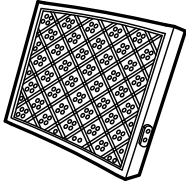
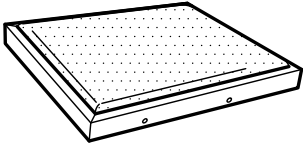
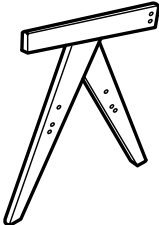
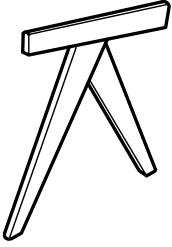
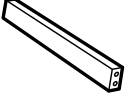

ASSEMBLY INSTRUCTION FOR ACME FURNITURE

MODEL#DN02373

Thank you for purchasing the quality product. Be sure to check all packing material carefully for small parts which may have come loose inside the carton during shipment. Separate, identify and count all parts and metal hardware. Compare with all parts list to be sure all parts are present. If any part(s) are missing or damaged, please contact your local furniture dealer. For efficient and speedy service, please indicate the model number and code letter of part(s) needed.

*** Do not fully tighten screws until fully assembled ***

COMPONENT PARTS		
DESCRIPTION	PART NAME	QTY (PCS)
①	CHAIR BACK 	2
②	SEAT 	2
③	LEFT SIDE LEG 	2
④	RIGHT SIDE LEG 	2
⑤	APRON 	4

HARDWARE REQUIRED

(A)		BOLT	M6 x 50mm	24 PCS
(B)		SPRING WASHER	5/16"	8 PCS
(C)		FLAT WASHER	M6 x 13mm	16 PCS
(D)		WOOD DOWEL	M8 x 30mm	8 PCS
(E)		ALLEN KEY	M4 x 100mm	1 PC

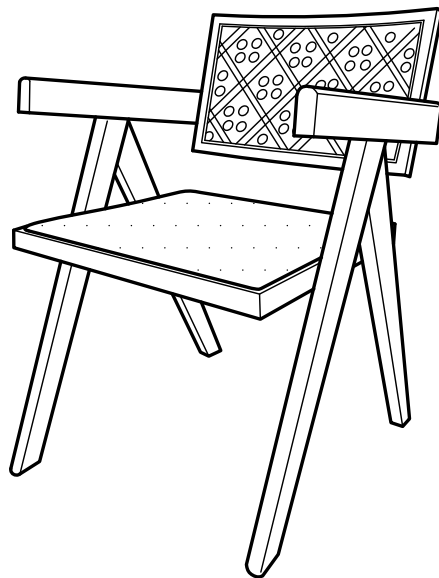

Attention

*** Some number parts listed on the instruction sheet may not be in parts bag as they already be assembled. Carefully check parts and packing materials prior to ordering replacements.

How to assemble :

STEP 1

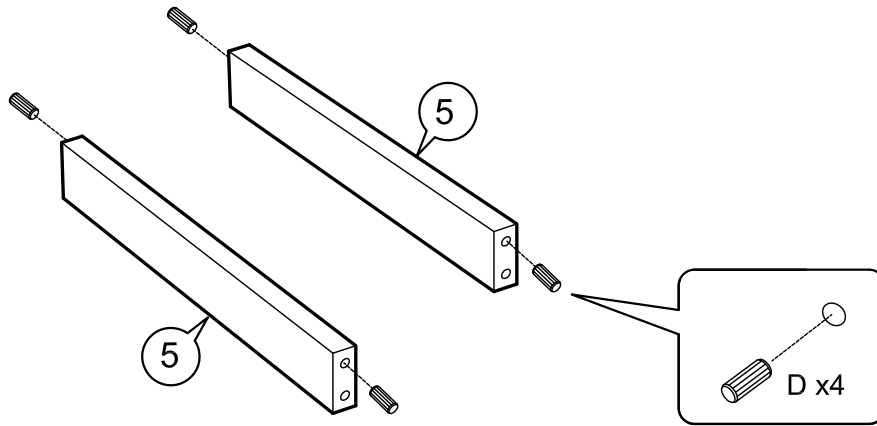

(x2)

STEP 2

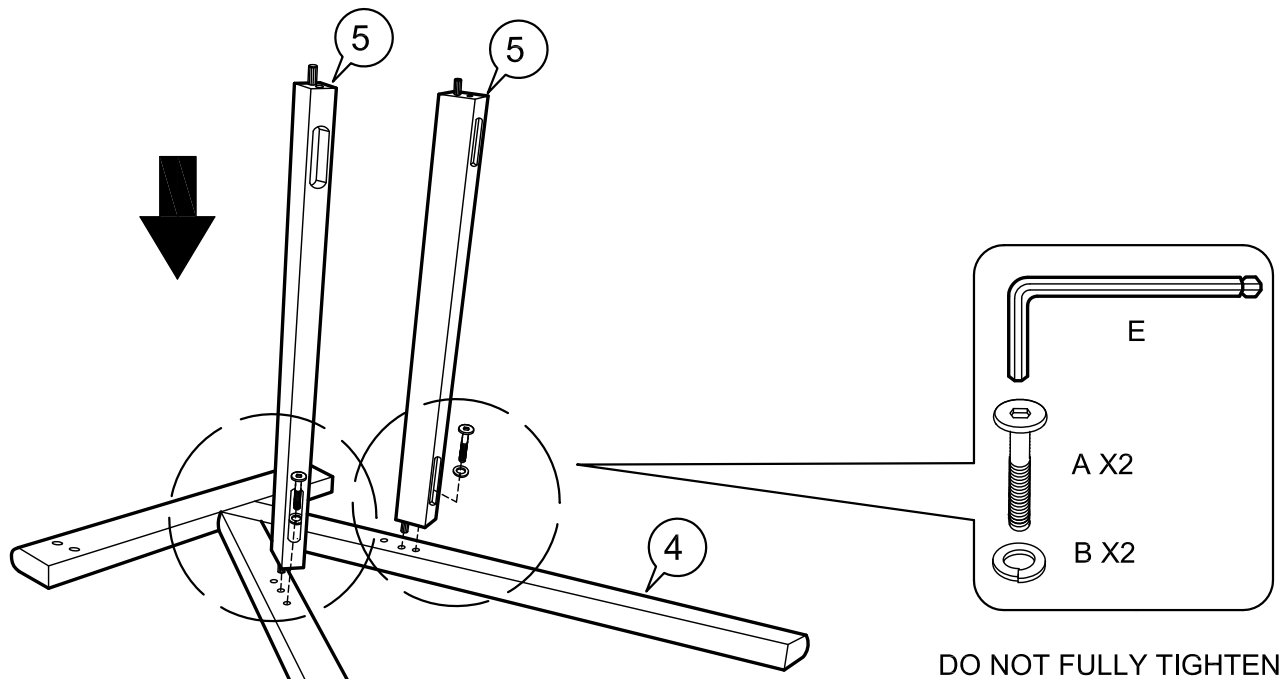

(x2)

STEP 3

DO NOT FULLY TIGHTEN

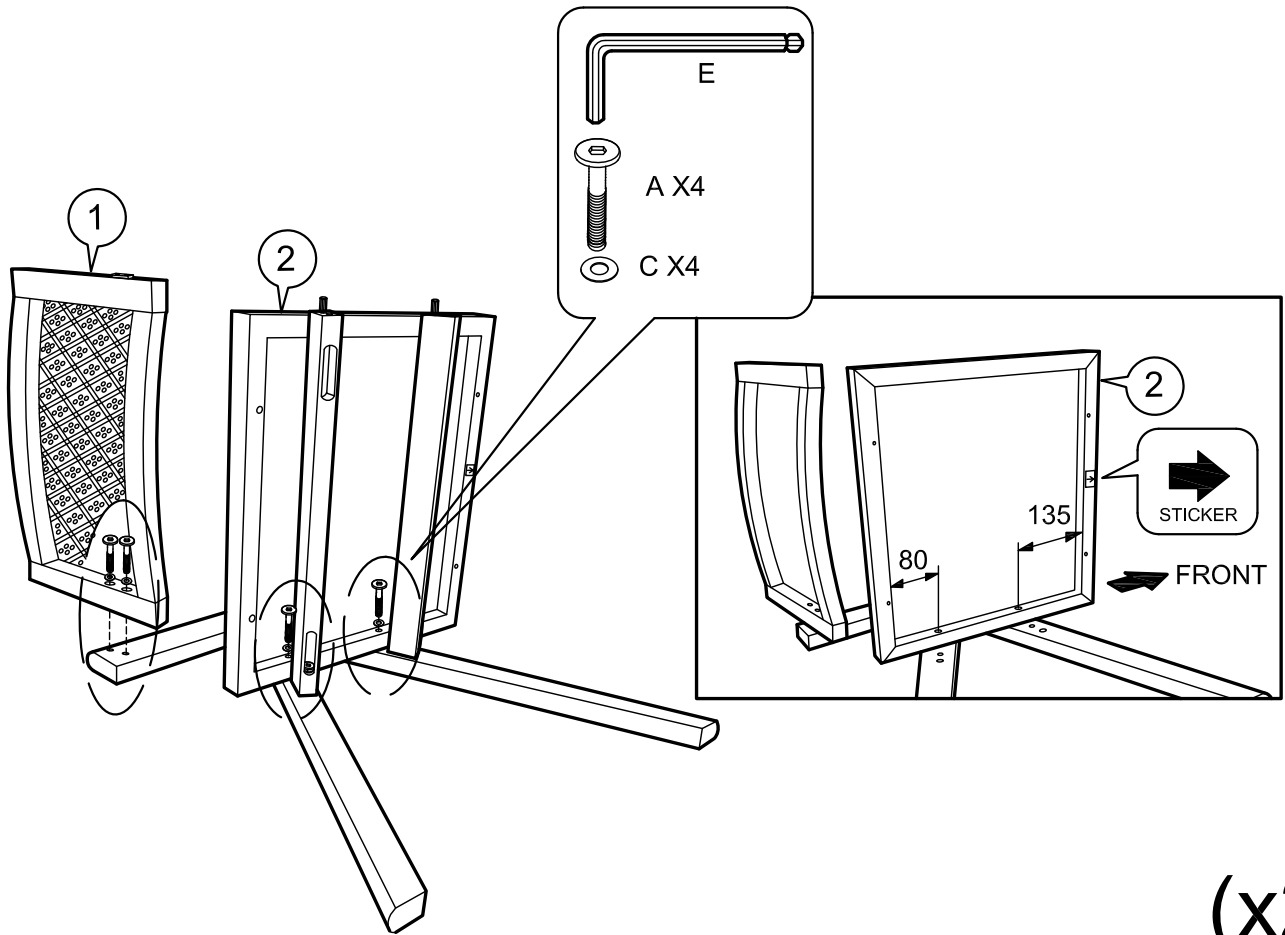

STEP 4

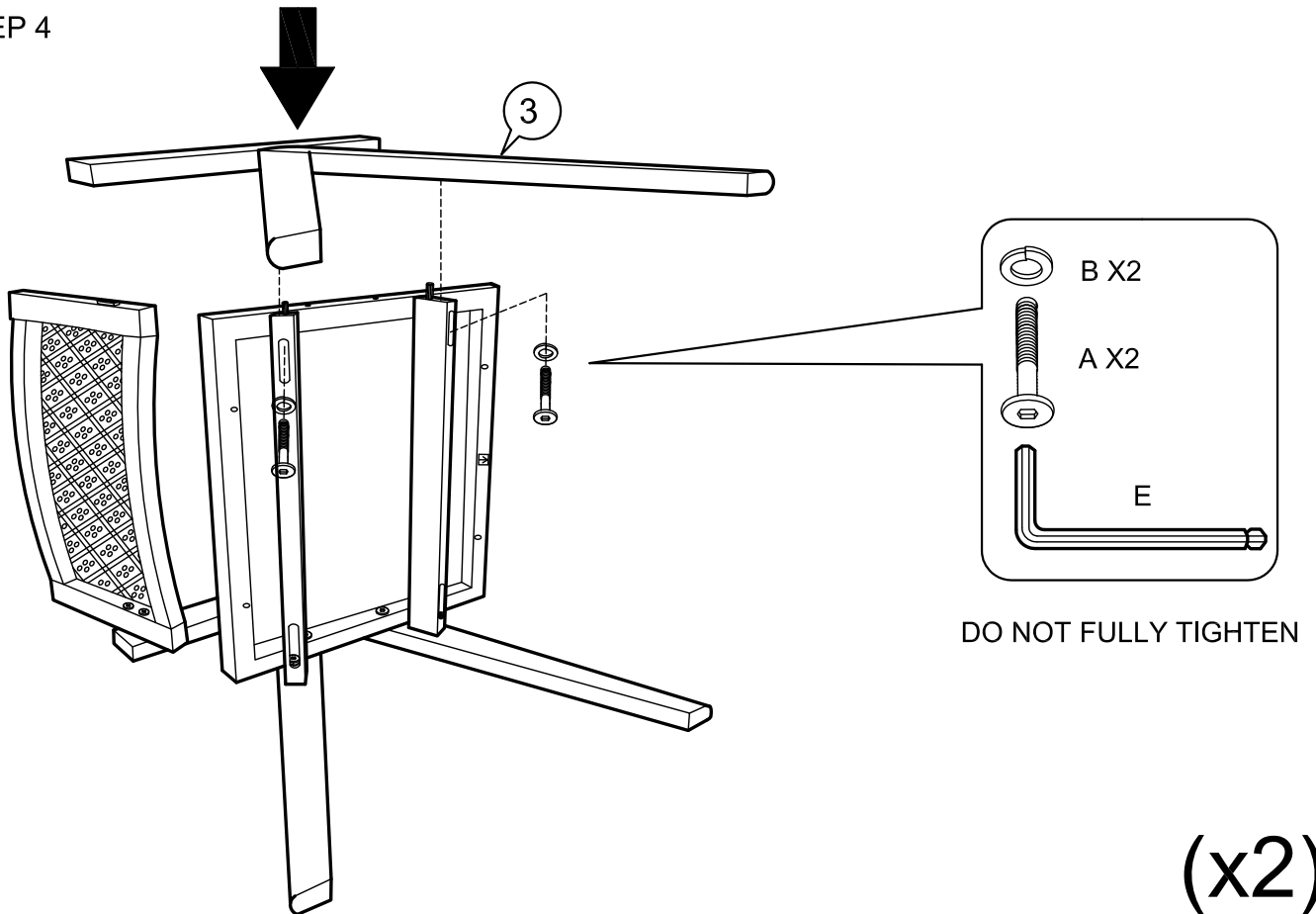

STEP 5

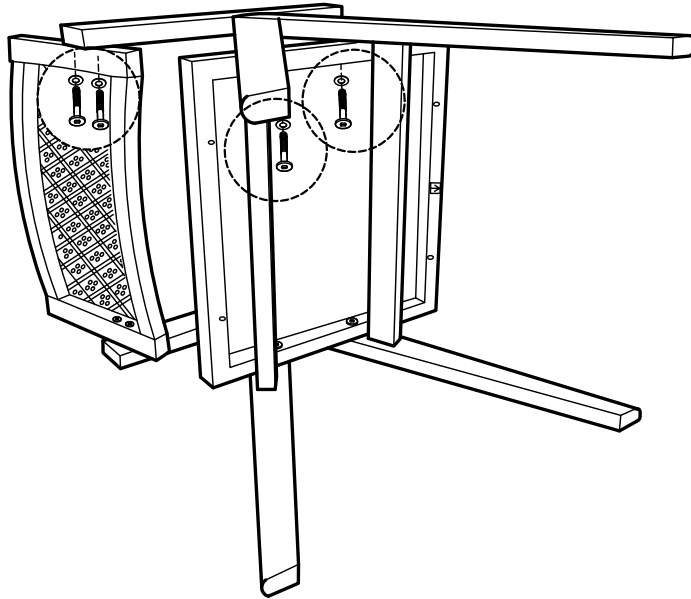
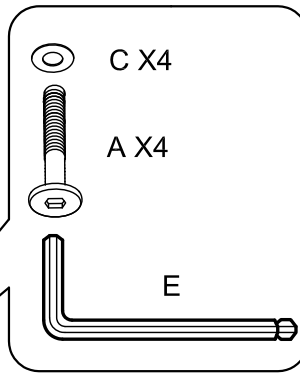

(x2)

STEP 6

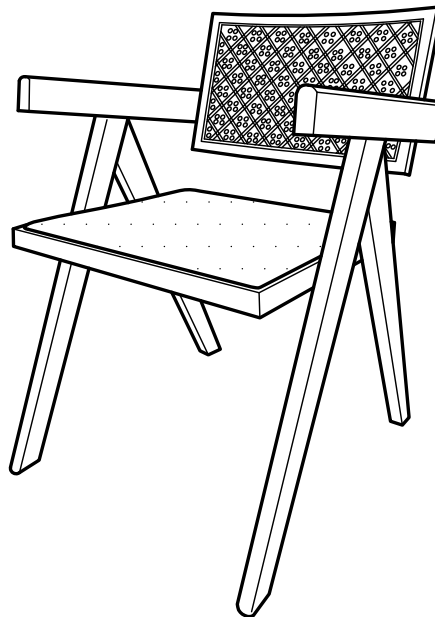

FULLY TIGHTEN ALL BOLTS

(x2)