

ASSEMBLY INSTRUCTION FOR ACME FURNITURE

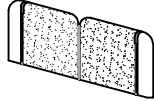

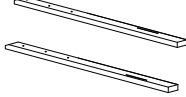

MODEL#BD03791EK1

Thank you for purchasing this quality product. Be sure to check all packing material carefully for small parts which may have loose inside the carton during shipment. Separate, identify and count all parts and metal hardware. Compare with all parts list to be sure all parts are present. If any part(s) are missing or damaged, please contact your local furniture dealer. For efficient and speedy service, please indicate the model number and code letter of part(s) needed.

Do not fully tighten screw until fully assembled

COMPONENT PARTS		
DESCRIPTION	PART NAME	Q'TY (PCS)
Ⓐ	HEADBOARD 	1
Ⓑ	HEADBOARD POST - (L/R) 	2

HARDWARE REQUIRED

NO	NAME	PART	QTY
1	Allen key		1pc
2	JCBC 40mm		6pcs
3	M6 Spring washer		6pcs
4	M6 Flat washer		6pcs
5	AC/DC Adapter		1pc

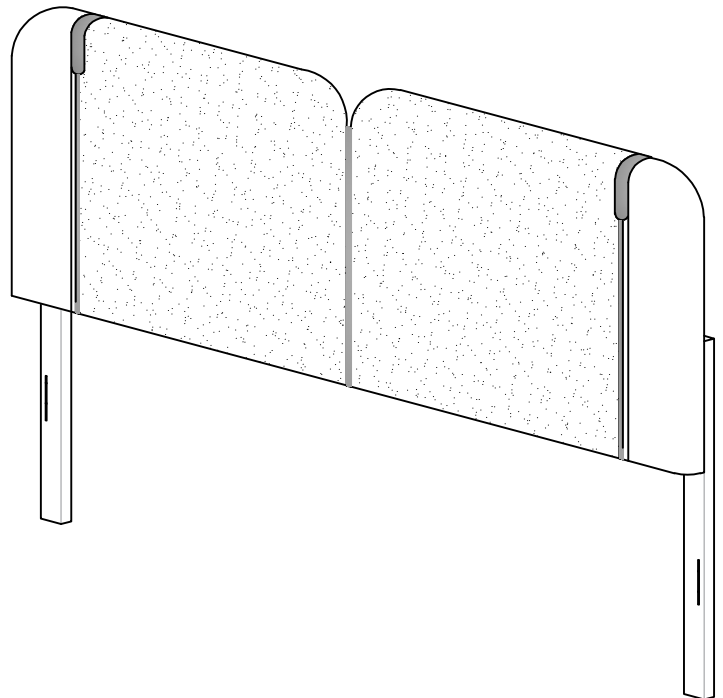

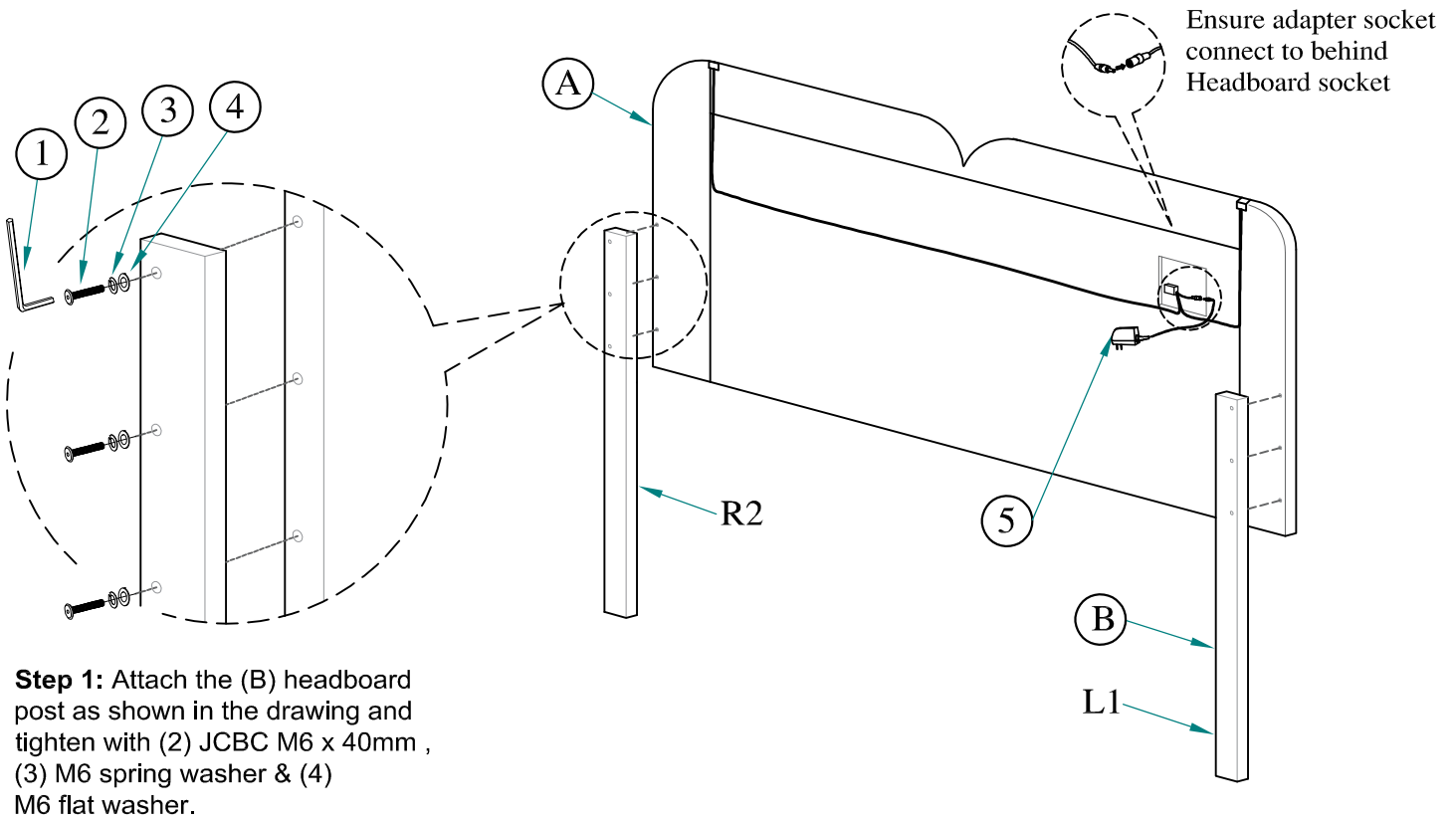

Step 1: Attach the (B) headboard post as shown in the drawing and tighten with (2) JCBC M6 x 40mm , (3) M6 spring washer & (4) M6 flat washer.

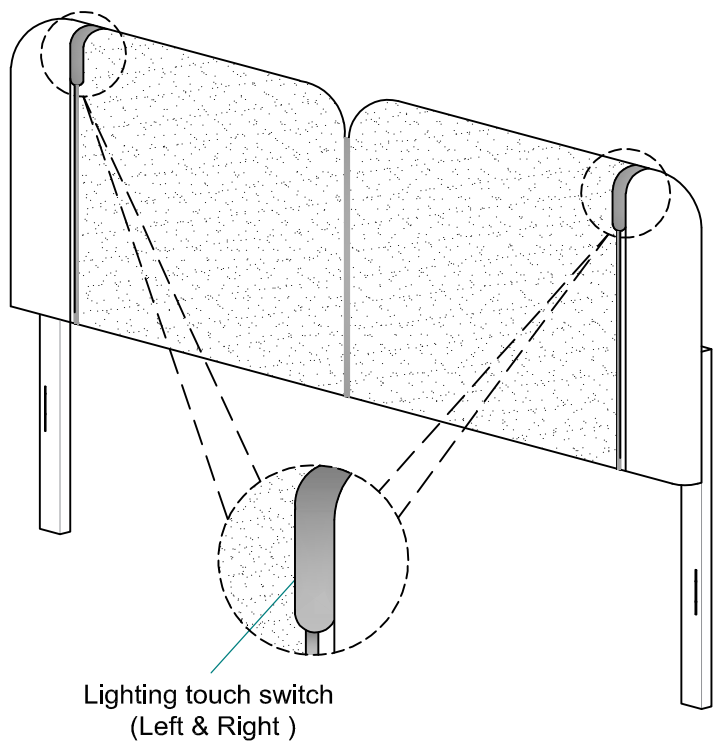





ASSEMBLY INSTRUCTION FOR ACME FURNITURE



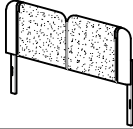
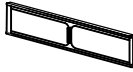

MODEL#BD03791EK1 / #BD03791EK2 / #BD03791EK3

Thank you for purchasing this quality product. Be sure to check all packing material carefully for small parts which may have loose inside the carton during shipment. Separate, identify and count all parts and metal hardware. Compare with all parts list to be sure all parts are present. If any part(s) are missing or damaged, please contact your local furniture dealer. For efficient and speedy service, please indicate the model number and code letter of part(s) needed.

*****Do not fully tighten screw until fully assembled*****

COMPONENT PARTS			
DESCRIPTION	PART NAME		Q'TY (PCS)
(A)	HEADBOARD		1
(B)	FOOTBOARD		1
(C)	SIDE RAIL		2
(D)	SLAT		4
(E)	SLAT SUPPORT LEG		8
(F)	BUN FOOT		2

HARDWARE REQUIRED

NO	NAME	PART	QTY
1	Allen key		1pc
2	JCBC 35mm		8pcs
3	M6 Spring washer		8pcs
4	Screw 32mm		8pcs
5	Adjustable Leveler		8pcs

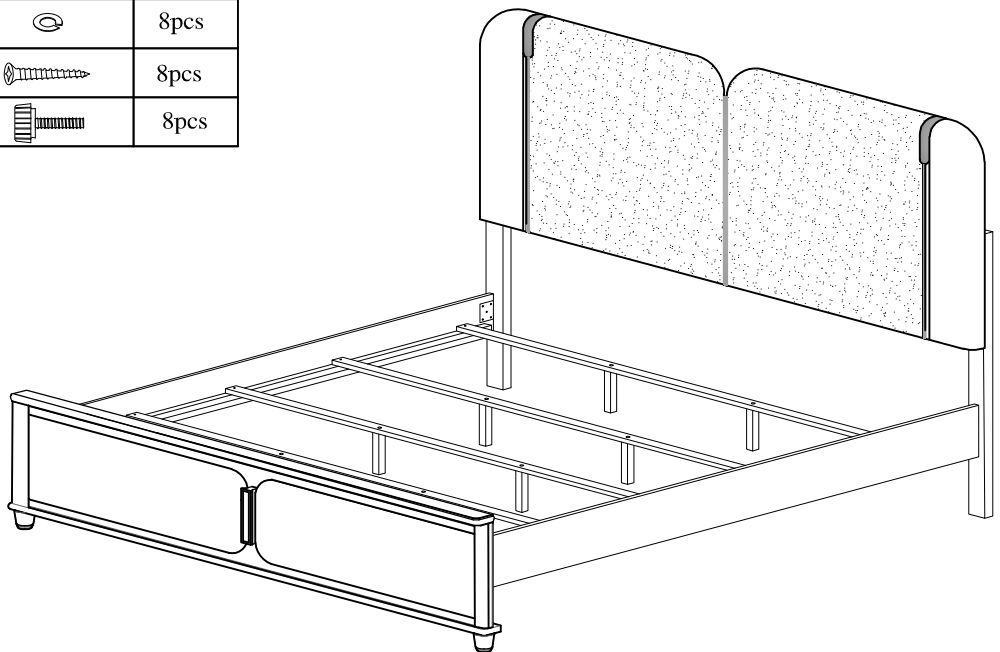

Step 1:

Secure the (F) Bun Foot to the bottom of (B) Footboard as a diagram shown.

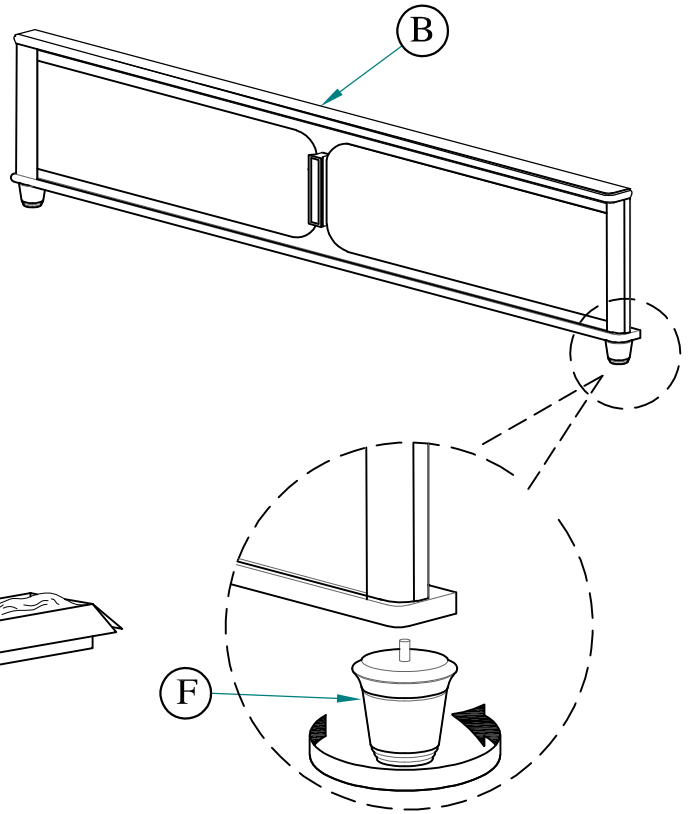

Bun Foot cover



Remove Bun Foot cover before assemble.

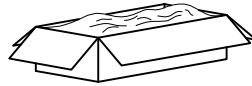

Step 2 :

Attach the (C) Side Rail to the (A) Headboard & (B) Footboard.

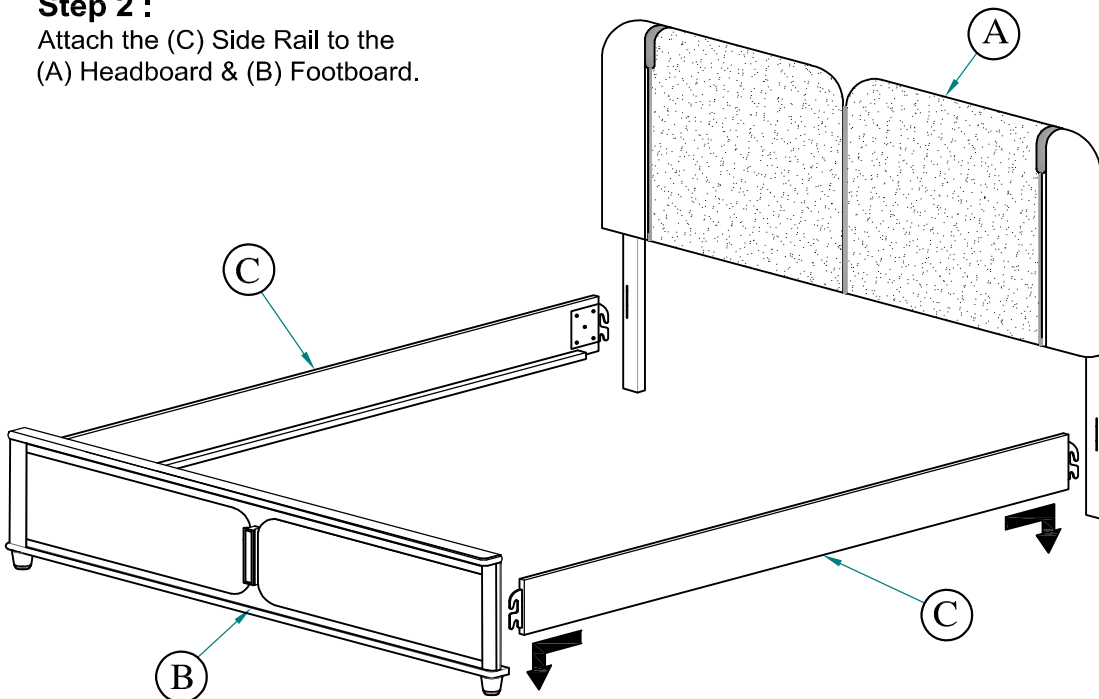

Step 3 :
Secure the (D) Slat using the
(4) Screw 32mm provided.

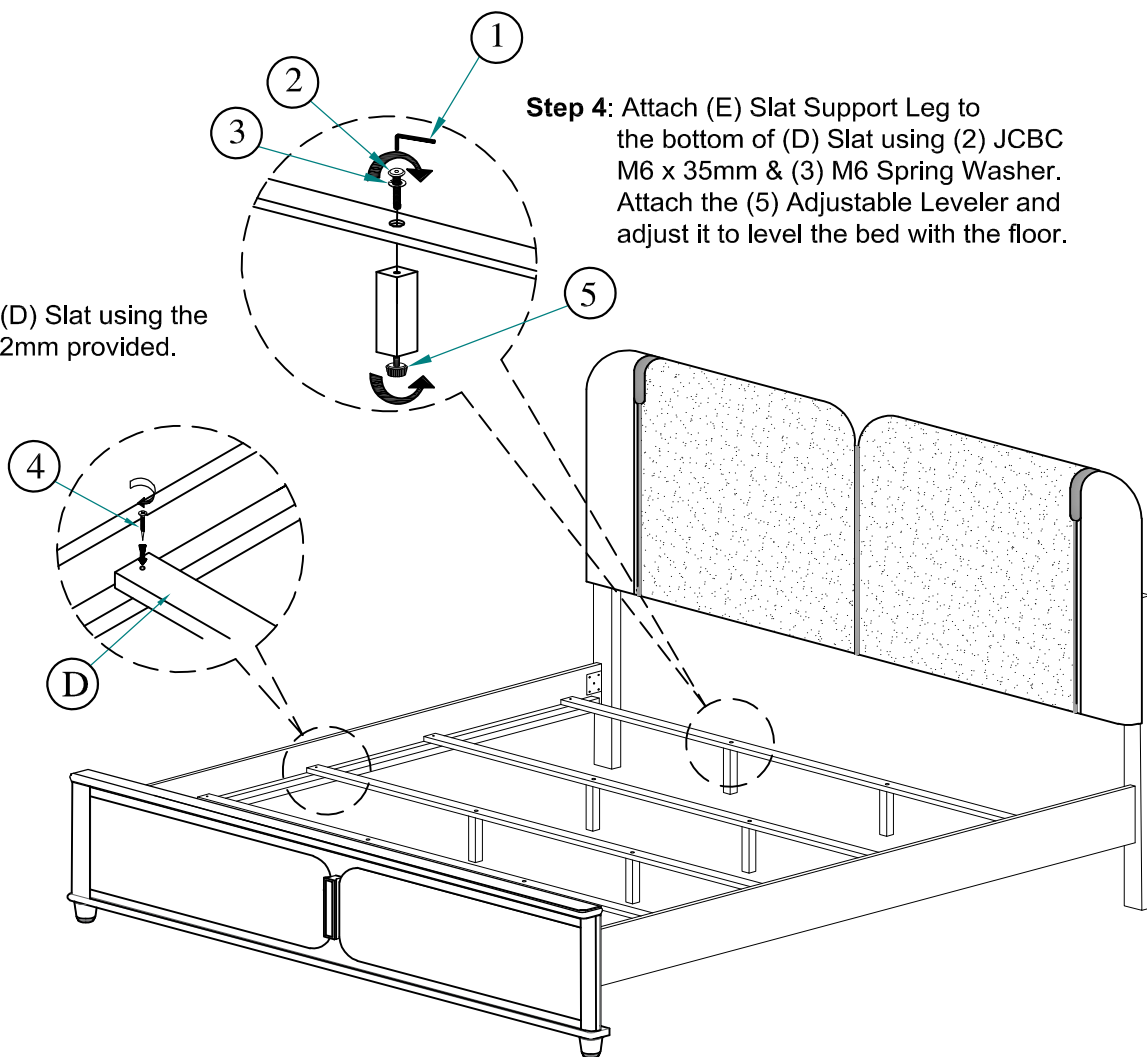

Step 4: Attach (E) Slat Support Leg to the bottom of (D) Slat using (2) JCBC M6 x 35mm & (3) M6 Spring Washer. Attach the (5) Adjustable Leveler and adjust it to level the bed with the floor.

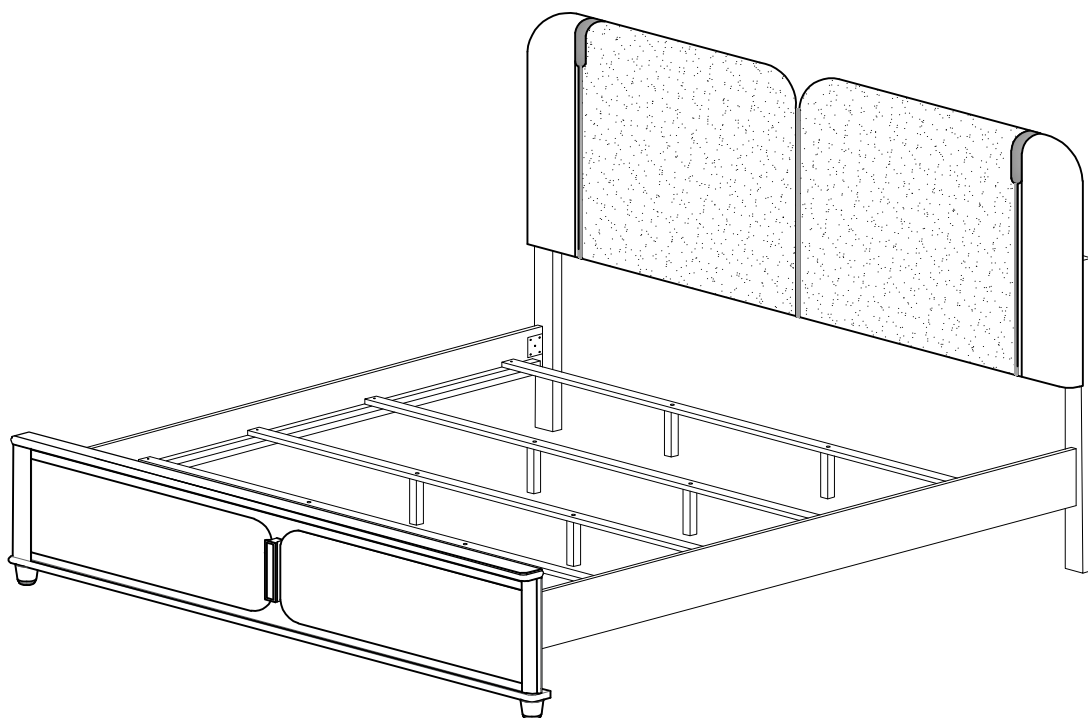

Assembly completed