

# ASSEMBLY INSTRUCTION FOR ACME FURNITURE

## MODEL#97787

Thank you for purchasing the quality product. Be sure to check all packing material carefully for small parts which may have come loose inside the carton during shipment. Separate, identify and count all parts and metal hardware. Compare with all parts are present. If any part(s) are missing or damaged, please contact your local furniture dealer. For efficient and speedy service, please indicate the model number and code letter of part(s) needed.

**\*\*\*Do not fully tighten screws until fully assembled.\*\*\***

## SHOE CABINET

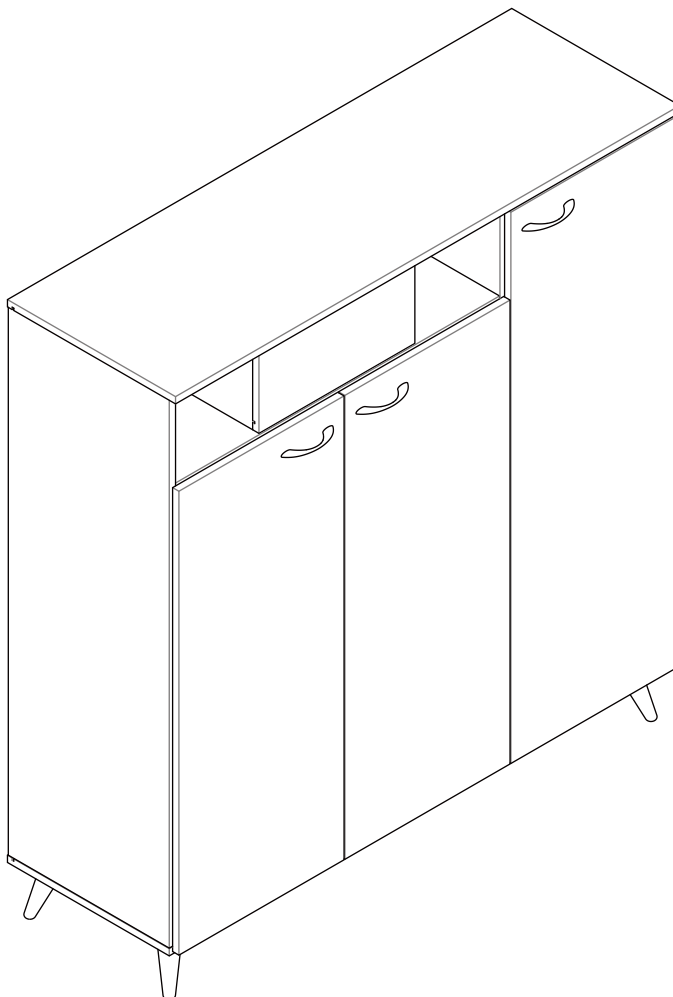

### DIMENSIONS

Width - 47.24"  
Depth - 15.75"  
Height - 50.08"

97787

# PARTS LIST

**A** X1 Top

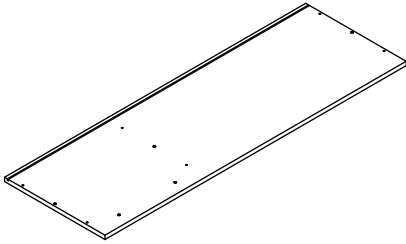

**B** X1 Left side

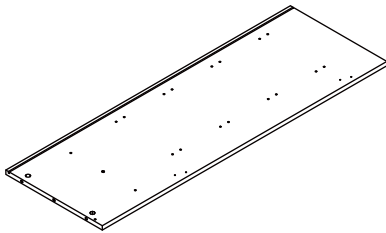

**C** X1 Right side

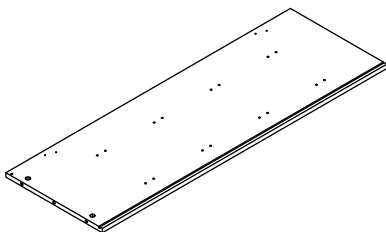

**D** X1 Bottom

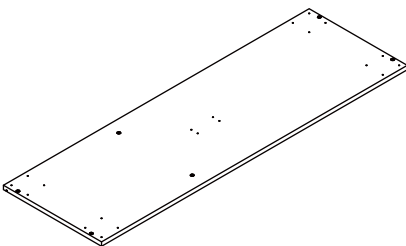

**E** X1 Middle

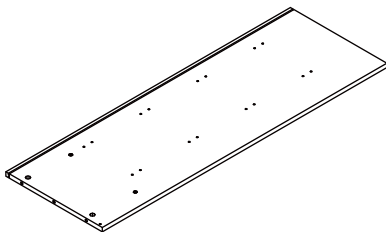

**F** X1 Middle top

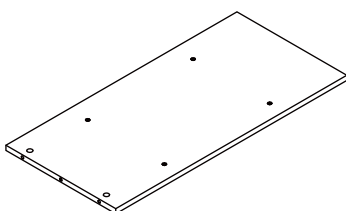

**G** X1 Large support

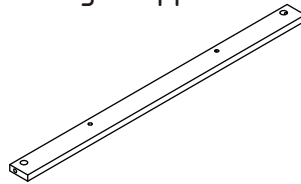

**H** X1 Small support

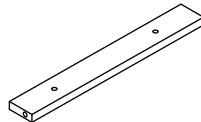

**I** X1 Small left side

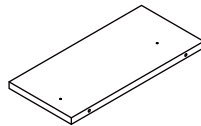

**J** X1 Small right side

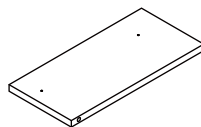

**K** X4 Large layer

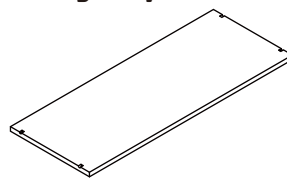

**L** X4 Small layer

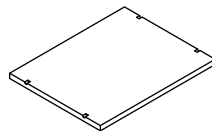

**M** X1 Left door

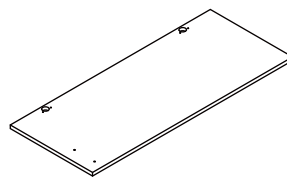

**N** X1 Right door

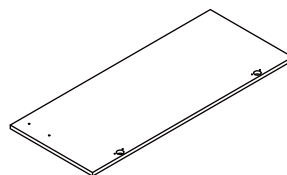

**O** X1 Large door

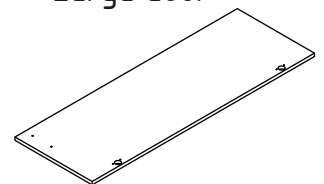

**P** X1 Drawer head

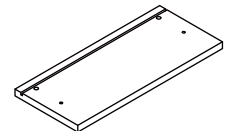

**Q** X1 Drawer left

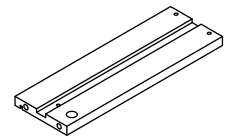

**R** X1 Drawer right

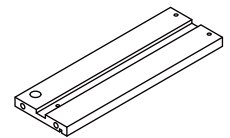

**S** X1 Drawer back

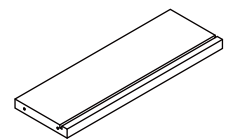

**T** X1 Drawer bottom

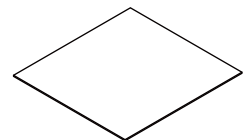

**U** X1 Right back

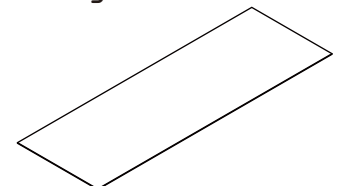

**V** X1 Left back

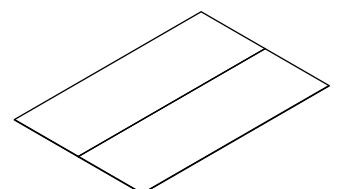

# HARDWARE LIST

① X14 Cam bolt 7\*35\*12.5mm



② X14 Cam lock 15\*12mm



③ X8 Dowel 8\*30mm



④ X4 Wood screw 8#\*1-3/4"

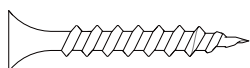

⑤ X12 Coarse screw 7\*11\*50mm

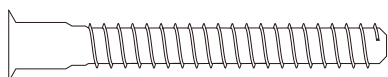

⑥ X2 Slide rail 17\*310mm

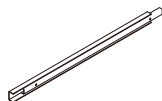

⑦ X4 Wood screw #6\*1/2"

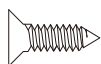

⑧ X2 Fixing screw M4\*12mm

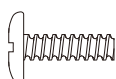

⑨ X32 Shelf pin 4.9\*16mm



⑩ X3 Handle



⑪ X6 Handle screw 7#\*19mm

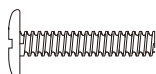

⑫ X6 Hinge ø26mm\*3/8

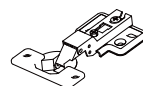

⑬ X24 Hinge screw 6#\*1/2"

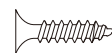

⑭ X8 Fixative plate

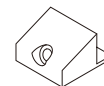

⑮ X8 Wood screw 3\*19mm



⑯ X2 Dowel 8\*20mm

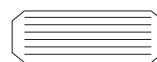

⑰ X4 Foot

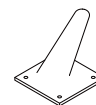

⑱ X1 Support foot



⑲ X20 T-head screw 4\*12mm



⑳ X1 Adjustable leveler 24mm\*1/4\*12mm

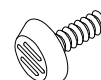

㉑ X1 Glue



㉒ X1 Allen wrench

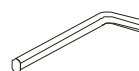

## Attention

Some number parts listed on the instruction sheet may not be in parts bag as they may already be assembled. Carefully check parts and packing materials prior to ordering replacements.

# ASSEMBLY INSTRUCTIONS

Step 1.

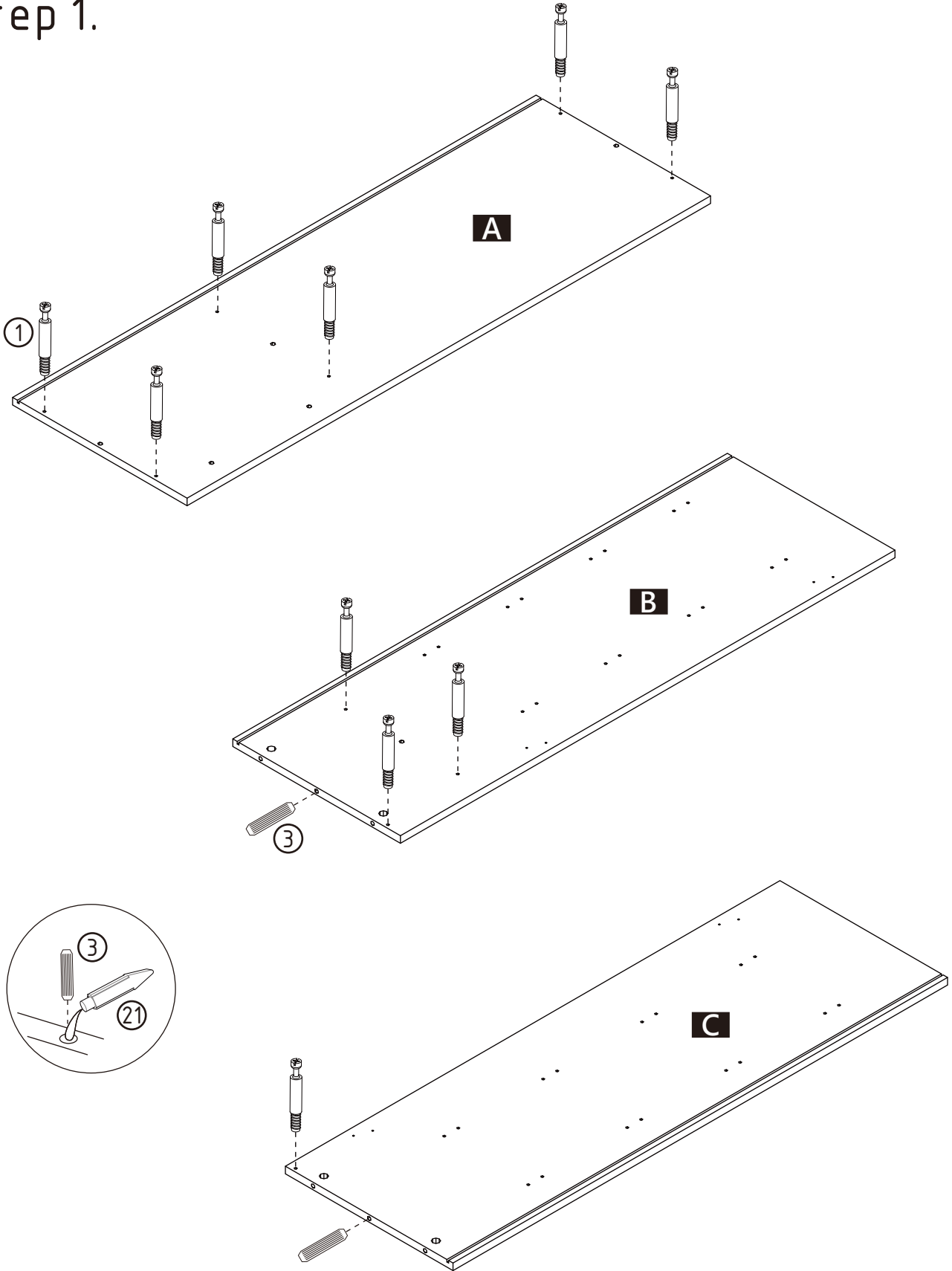

# ASSEMBLY INSTRUCTIONS

## Step 2.

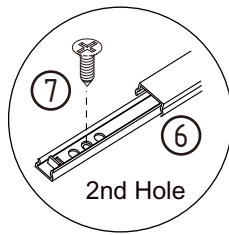
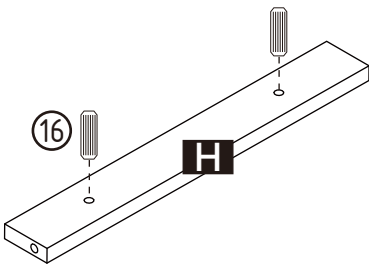
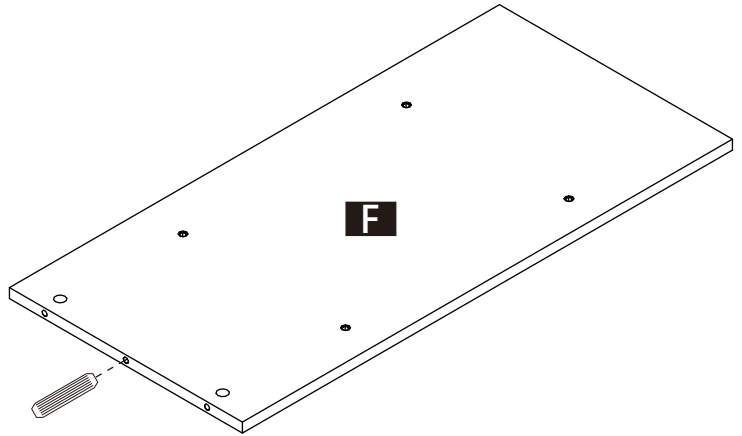
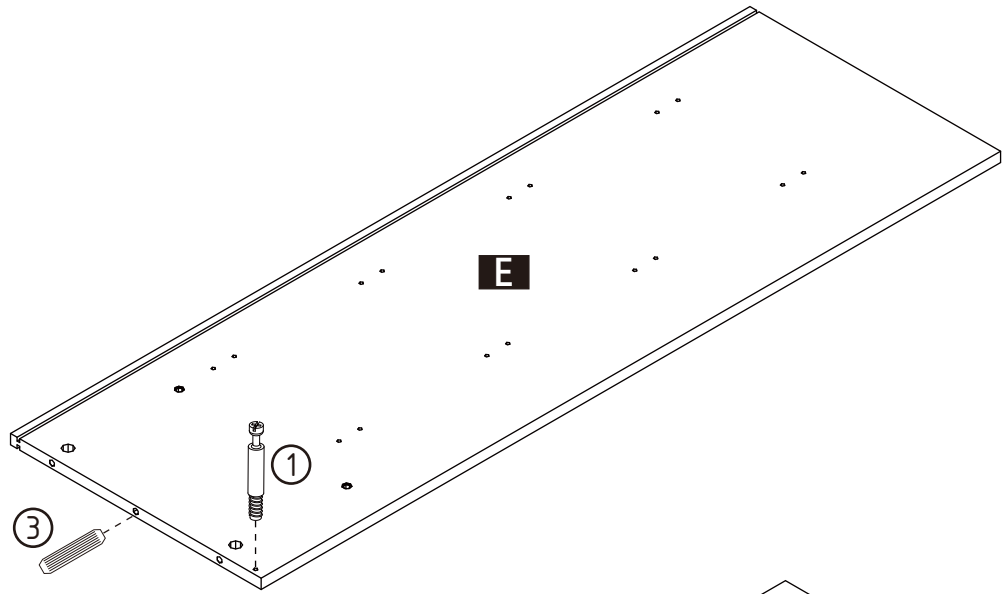
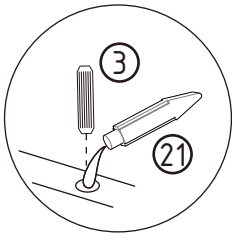

Push runner to see screw holes on the other end.

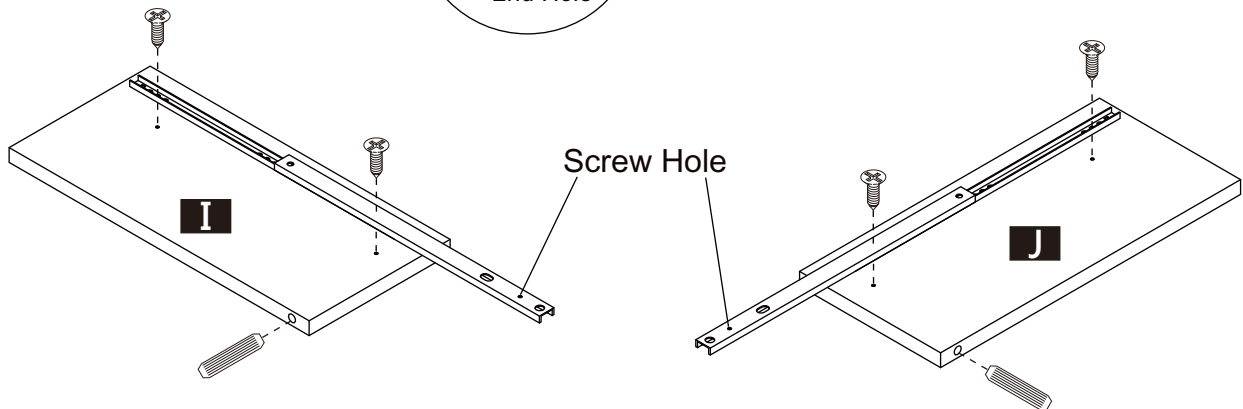

# ASSEMBLY INSTRUCTIONS

Step 3.

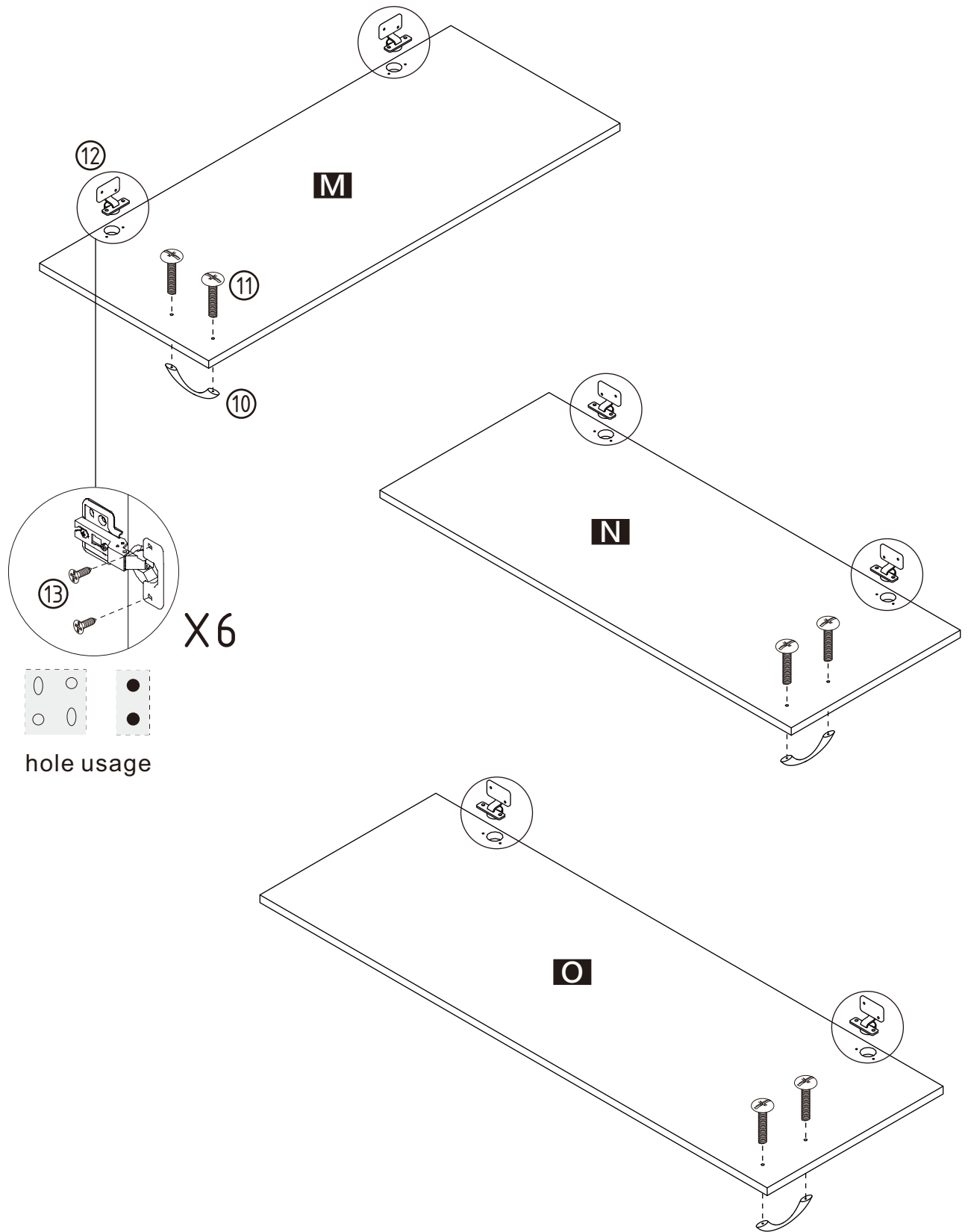

# ASSEMBLY INSTRUCTIONS

Step 4.

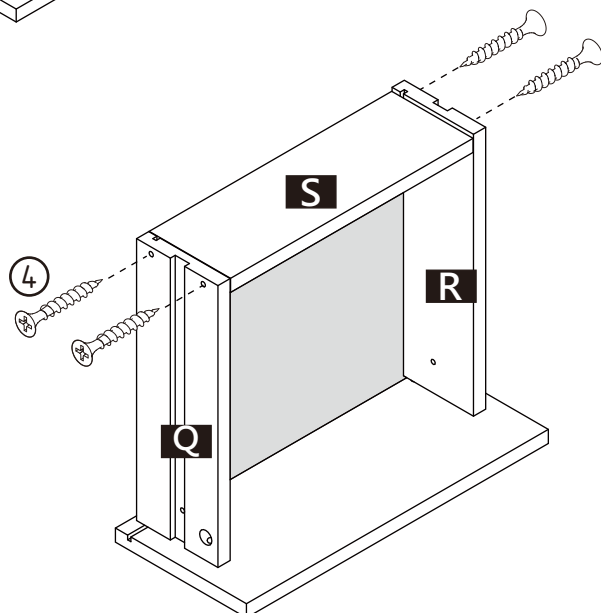
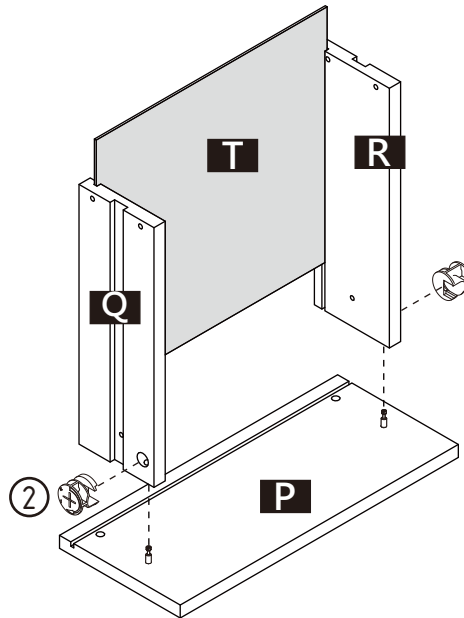
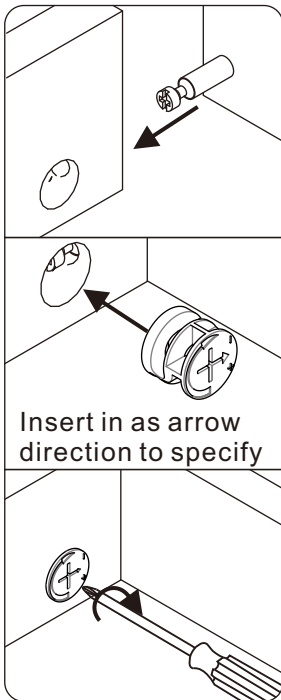
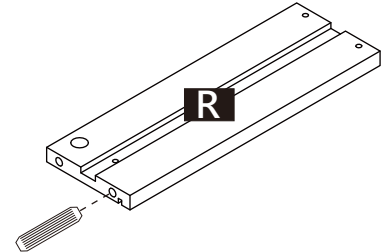
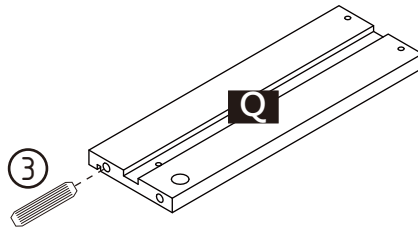
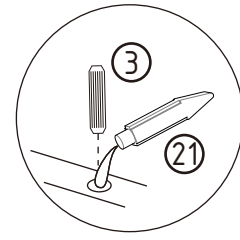
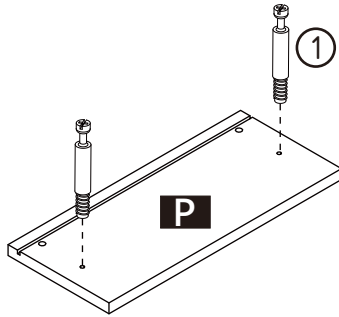

# ASSEMBLY INSTRUCTIONS

## Step 5.

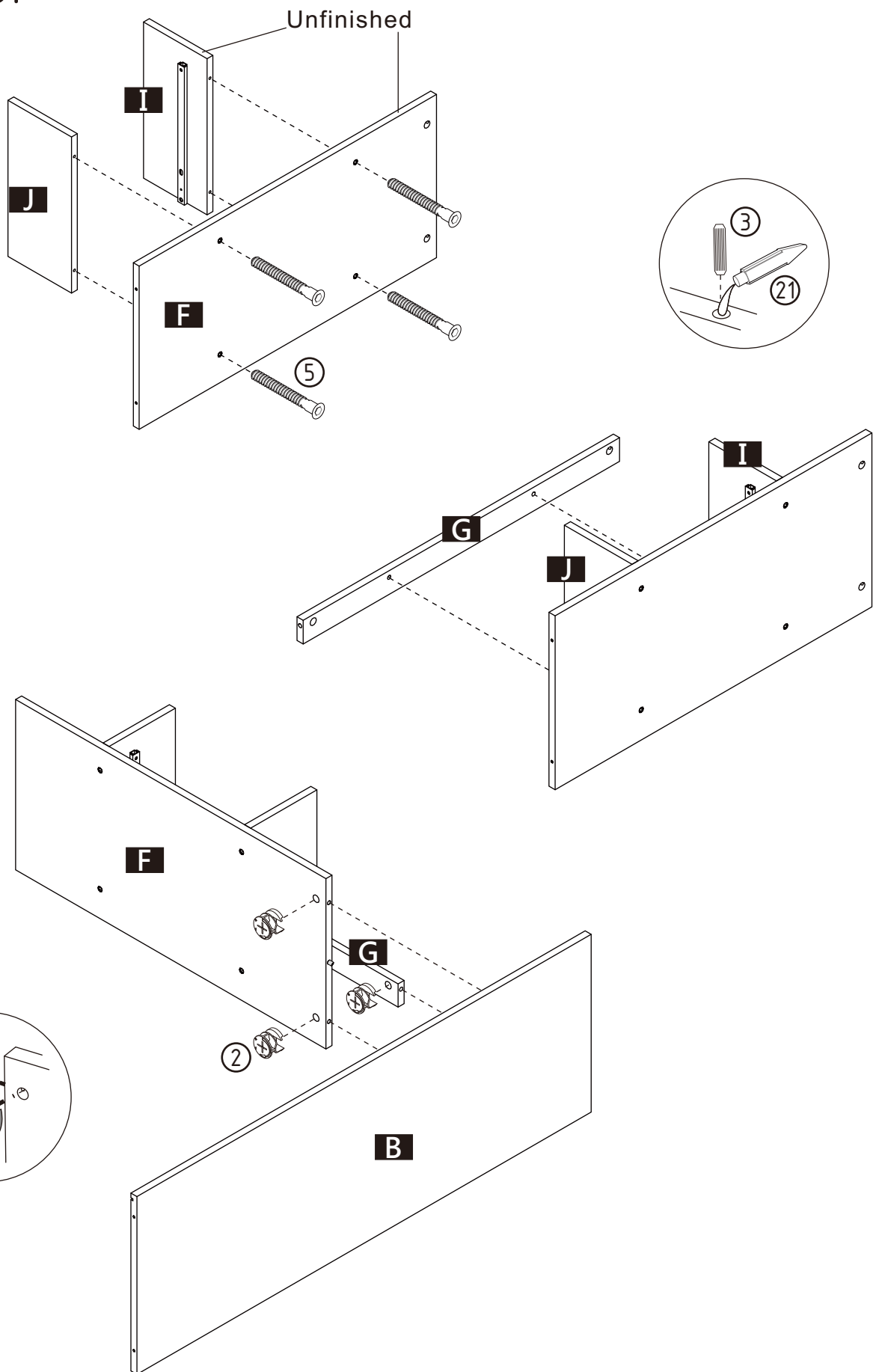



# ASSEMBLY INSTRUCTIONS

Step 6.

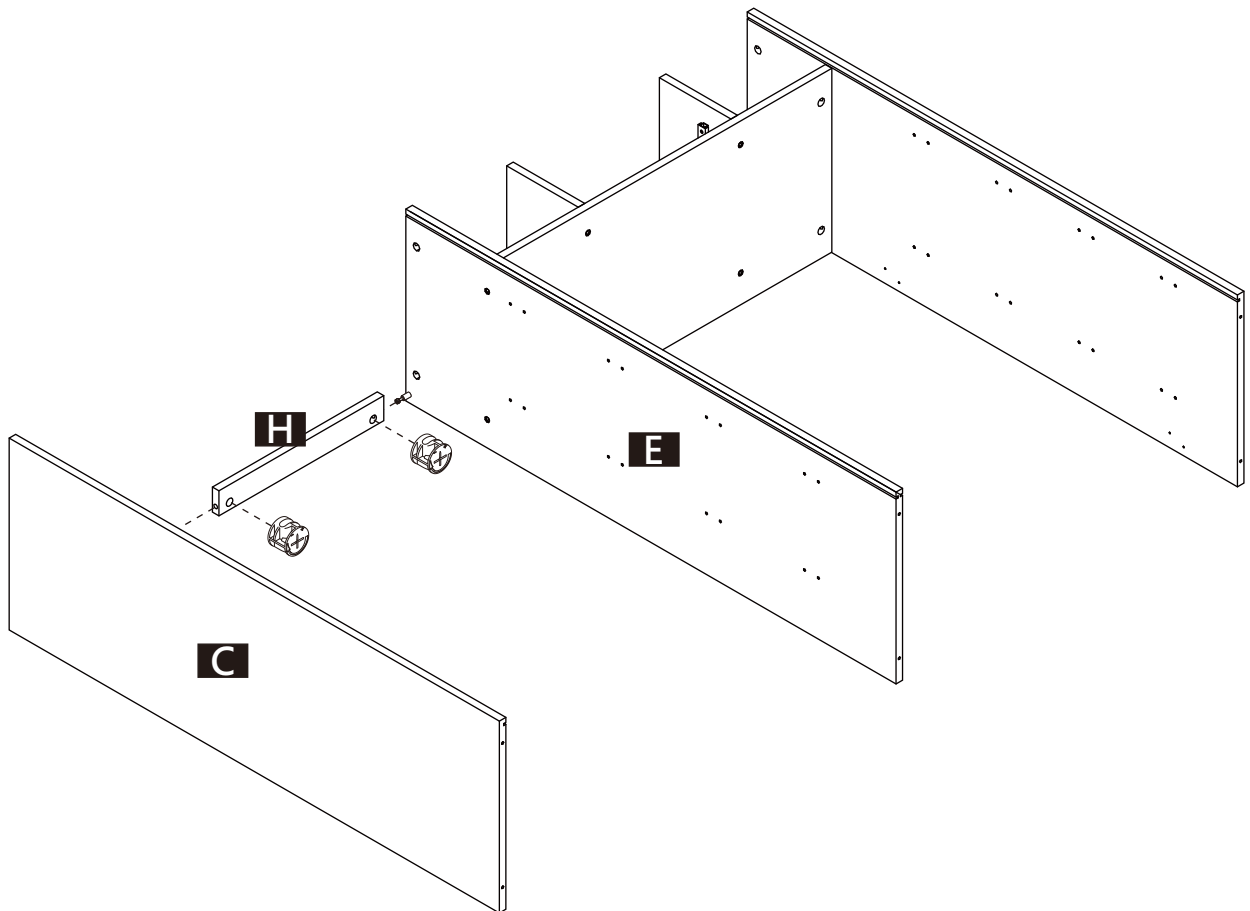
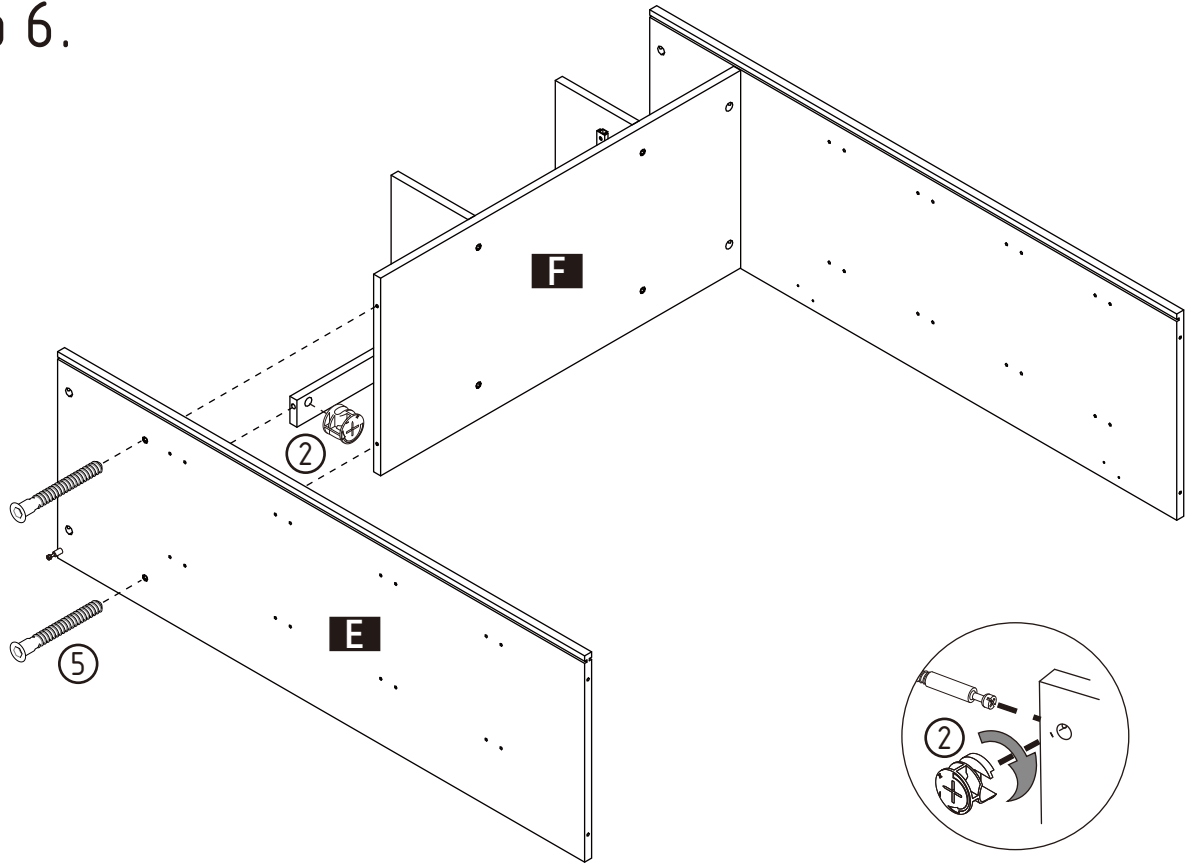

# ASSEMBLY INSTRUCTIONS

Step 7.

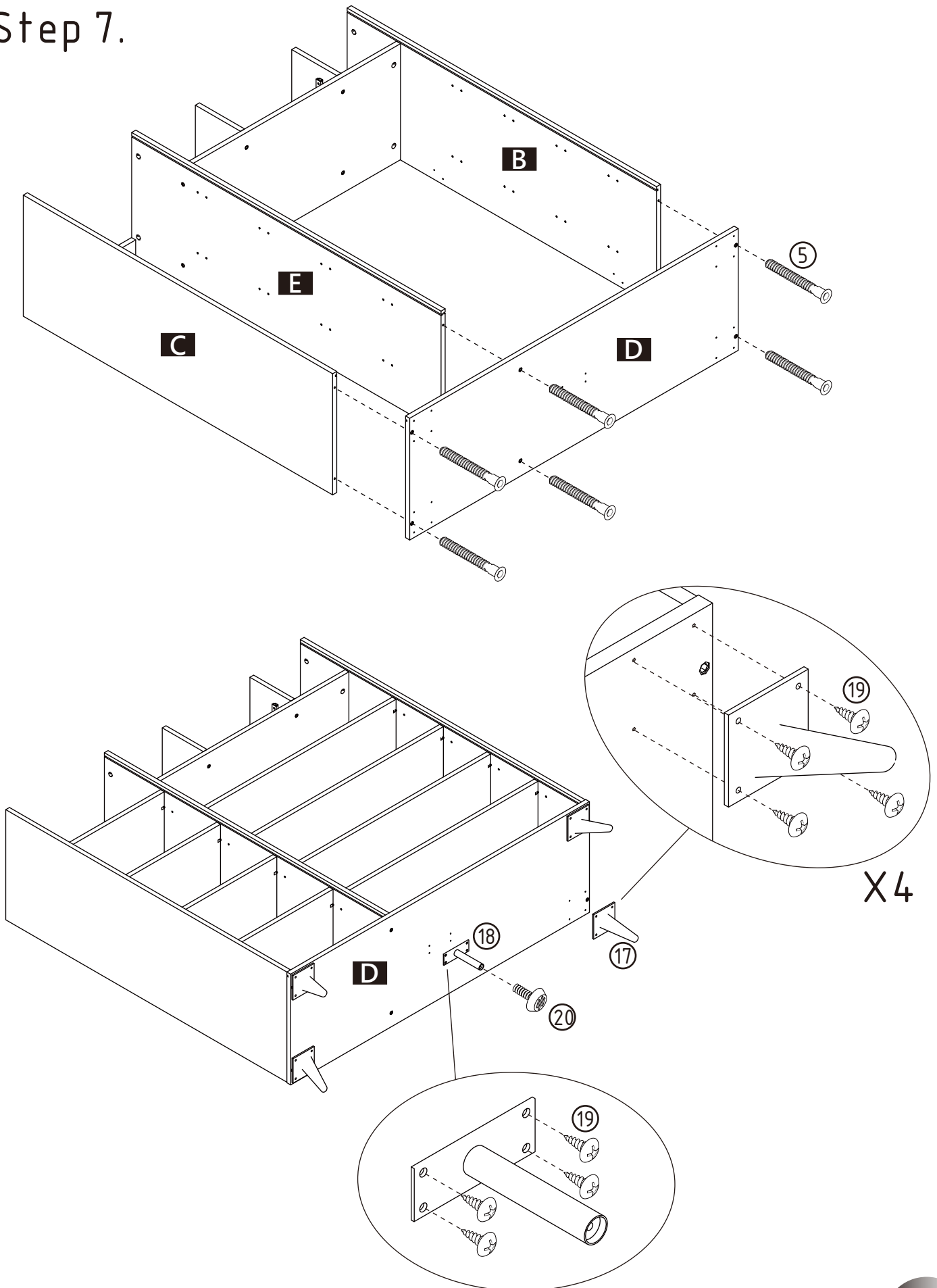

# ASSEMBLY INSTRUCTIONS

Step 8.

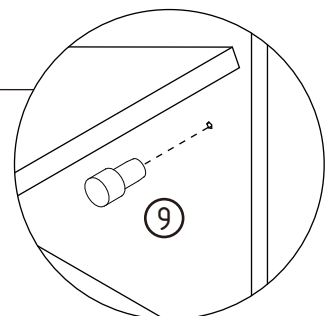
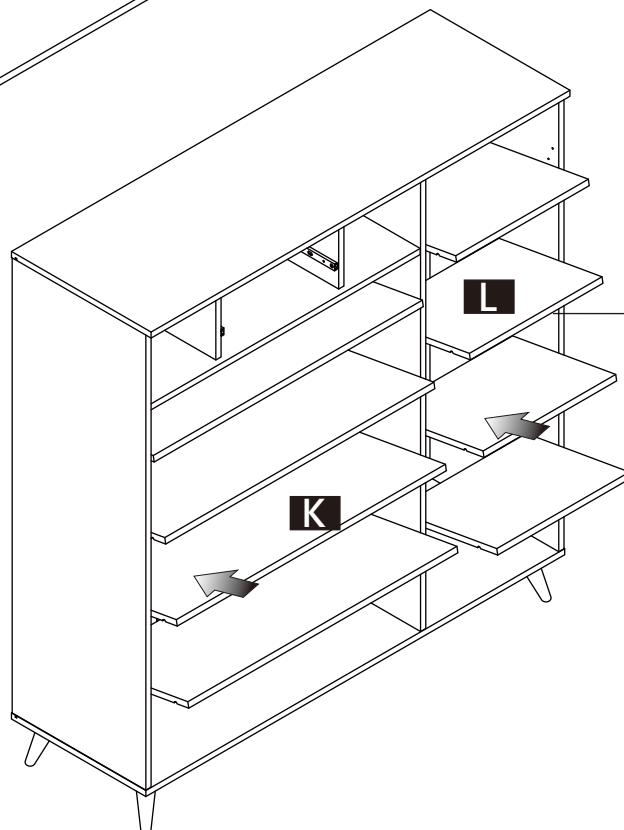
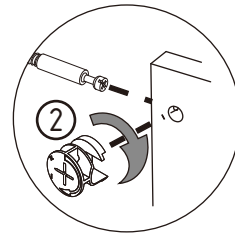
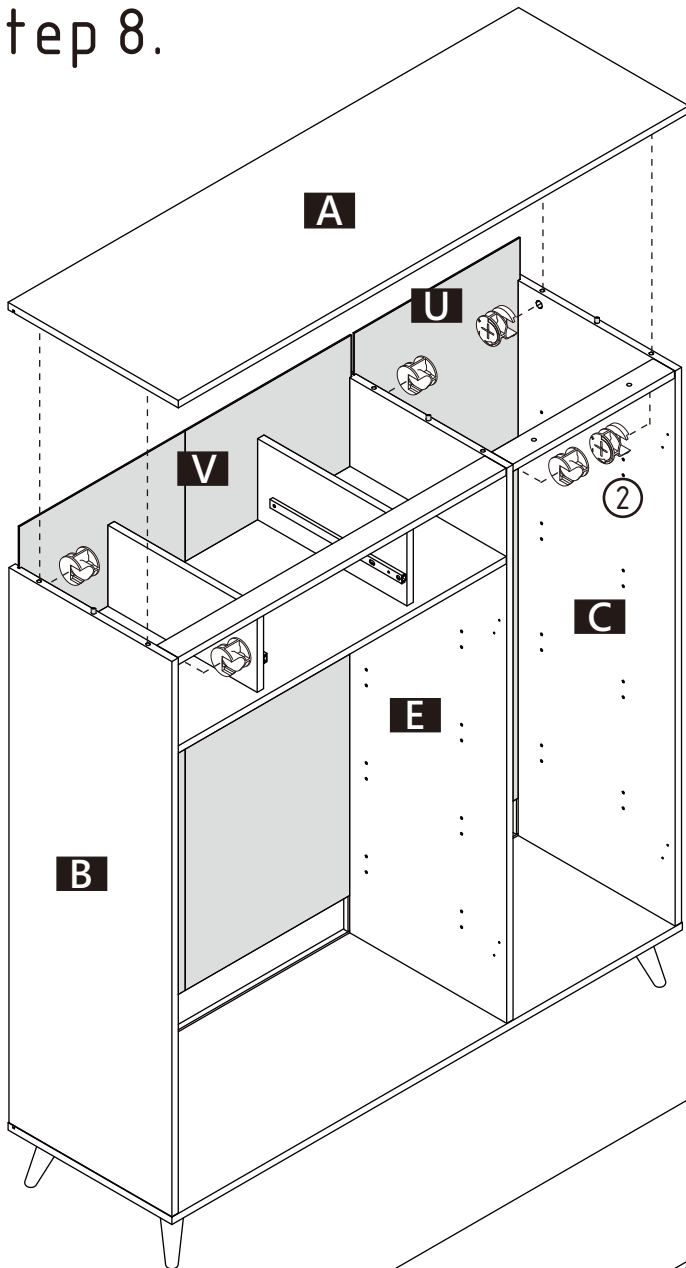

X32

# ASSEMBLY INSTRUCTIONS

## Step 9.

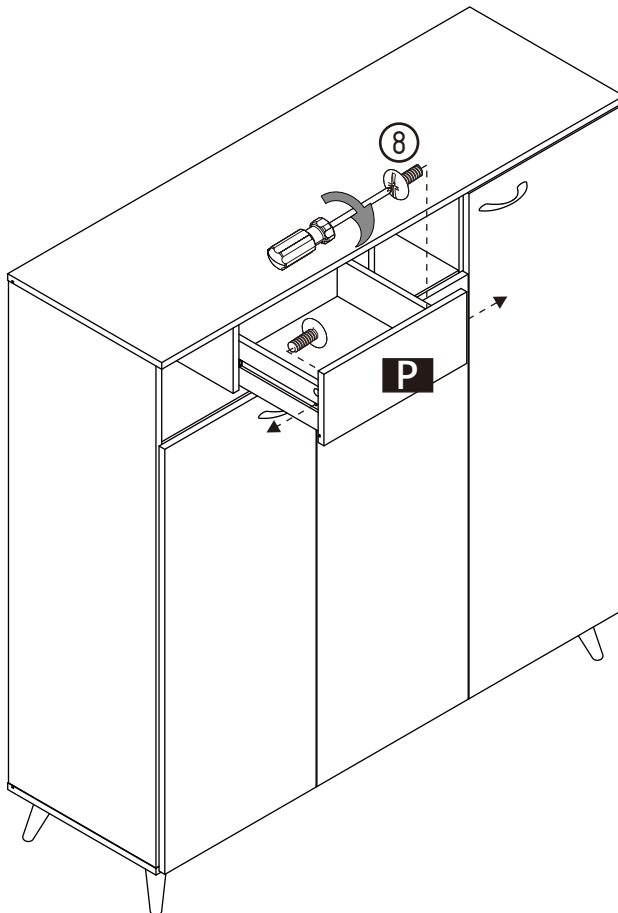
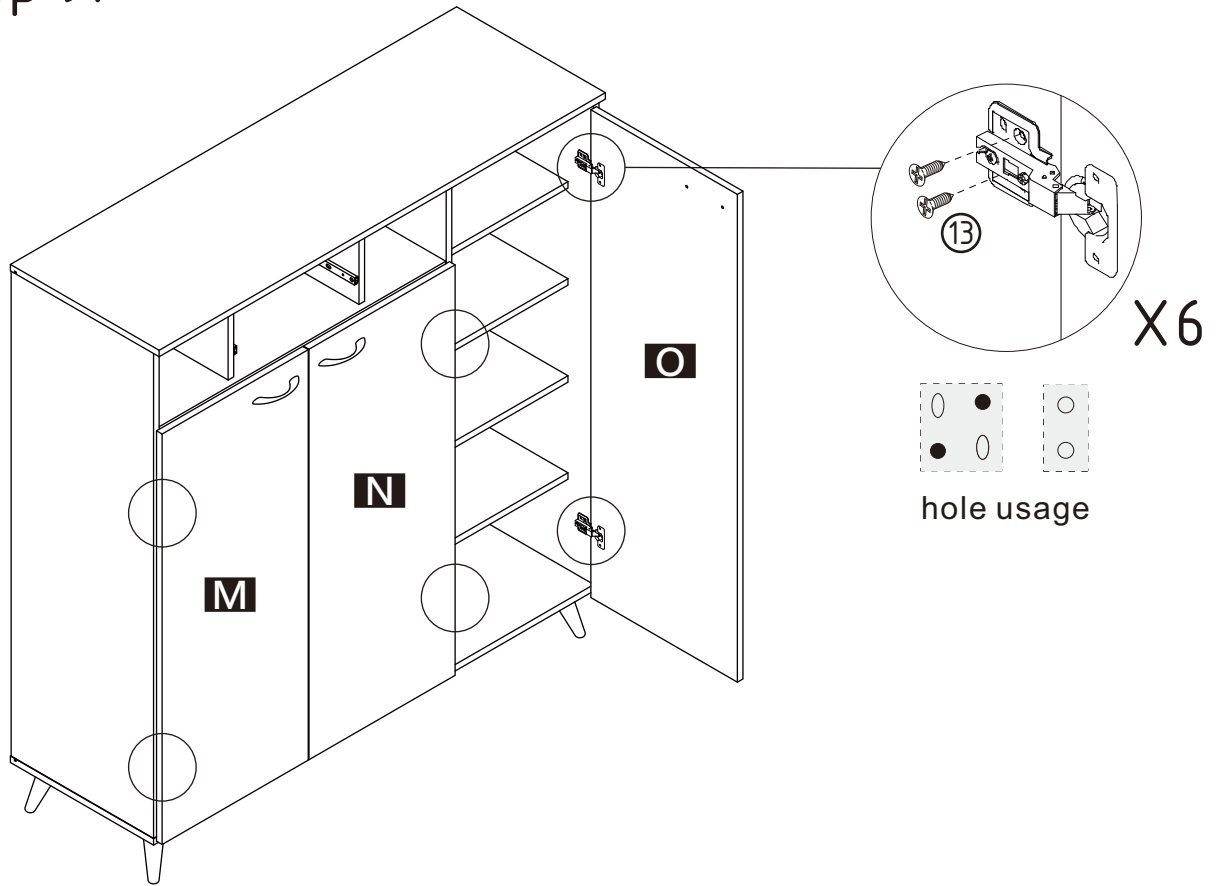

Extend the two outer slides of the runners so that they could align with the sides of the drawer. Make sure the pre-drilled holes from the drawer align with the screw holes of the outer slides. Secure two screws from the inside of the drawer using a Phillips screwdriver to tighten them to the outer slides.

# ASSEMBLY INSTRUCTIONS

Step 10.

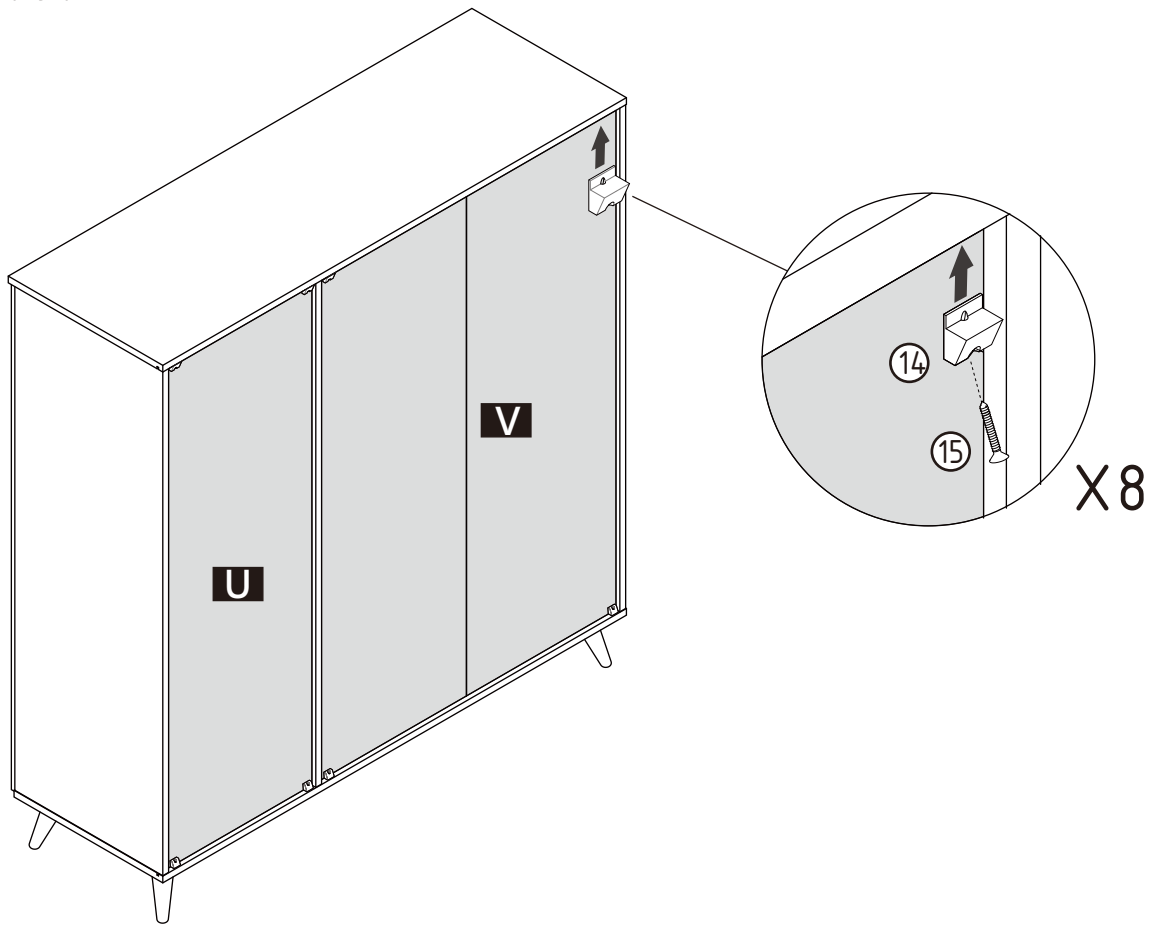

## ASSEMBLY IS COMPLETED.

Make sure the product is rested on a flat surface and does not feel loose or wobbly. If it does, double check that the bolts/screws are secured and properly tightened.