

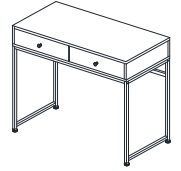

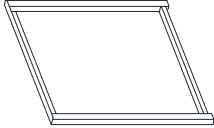







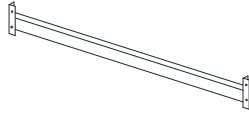
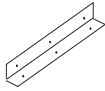
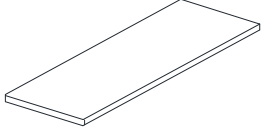
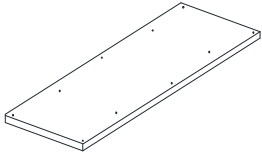
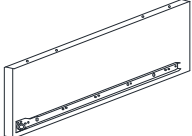
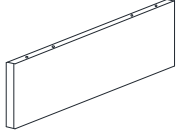
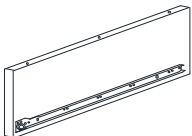
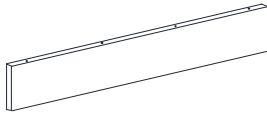
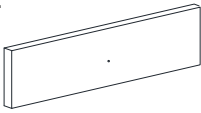
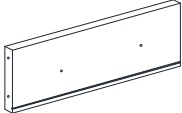
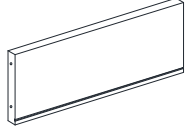
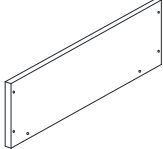
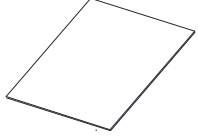
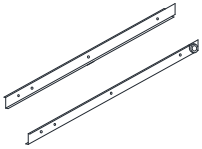

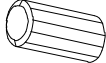
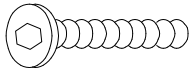
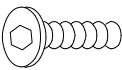
ITEM NO. 92312

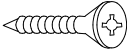
DESK

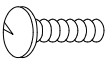

ASSEMBLY INSTRUCTIONS

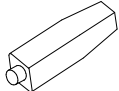
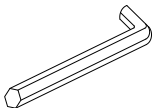
<p>1.</p>  <p>METAL SIDE PANEL 2PCS</p>	<p>2.</p>  <p>SUPPORT 2PCS</p>	<p>3.</p>  <p>STRETCHER 1PC</p>	<p>4.</p>  <p>L METAL 3PCS</p>	<p>5.</p>  <p>TOP BOARD 1PC</p>	
<p>6.</p>  <p>BOTTOM BOARD 1PC</p>	<p>7.</p>  <p>LEFT SIDE PANEL 1PC</p>	<p>8.</p>  <p>RIGHT SIDE PANEL 1PC</p>	<p>9.</p>  <p>MIDDLE PANEL 1PC</p>	<p>10.</p>  <p>BACK PANEL 1PC</p>	
<p>11.</p>  <p>DRAWER FRONT LEFT 1PC RIGHT 1PC</p>	<p>12.</p>  <p>DRAWER FRONT BOARD 2PCS</p>	<p>13.</p>  <p>DRAWER BACK BOARD 2PCS</p>	<p>14.</p>  <p>DRAWER SIDE BOARD 4PCS</p>	<p>15.</p>  <p>DRAWER BOTTOM BOARD 2PCS</p>	
<p>A.</p>  <p>METAL GLIDE L 2PCS / R 2PCS</p>	<p>B.</p>  <p>LEVELER 4PCS</p>	<p>C.</p>  <p>KNOB 2PCS</p>	<p>D.</p>  <p>WOOD DOWEL 22PCS</p>	<p>E.</p>  <p>BOLT 63mm 4PCS</p>	
<p>F.</p>  <p>BOLT 35mm 4PCS</p>	<p>G.</p>  <p>BOLT 12mm 4PCS</p>	<p>H.</p>  <p>SCREW 38mm 6PCS</p>	<p>I.</p>  <p>SCREW 25mm 16PCS</p>	<p>J.</p>  <p>SCREW 12mm 12PCS</p>	
<p>K.</p>  <p>BOLT 21mm 4PCS</p>	<p>L.</p>  <p>BOLT 19mm 2PCS</p>	<p>M.</p>  <p>SCREW 18PCS</p>	<p>N.</p>  <p>CAP 8PCS</p>	<p>O.</p>  <p>GLUE 1PC</p>	<p>P.</p>  <p>ALLEN KEY 1PC</p>

***** Do not tighten screws & bolts until the entire unit is completely assembled. *****

Drawer Assembly

STEP 1

Attach drawer side boards (14) to drawer back boards (13) using screws (I).

Insert drawer bottom boards (15) along the grooves of drawer side boards (14).

Attach drawer front boards (12) to drawer side boards (14) using screws (I).

Attach knobs (C) to Left/Right drawer front panel (11) using Philips head bolts (L).

Attach Left/Right metal glides (A) to each of the assembled drawer boxes using screws (J).

Attach Left/Right drawer front panel (11) to drawer front boards (12) using Philips head bolts (K).

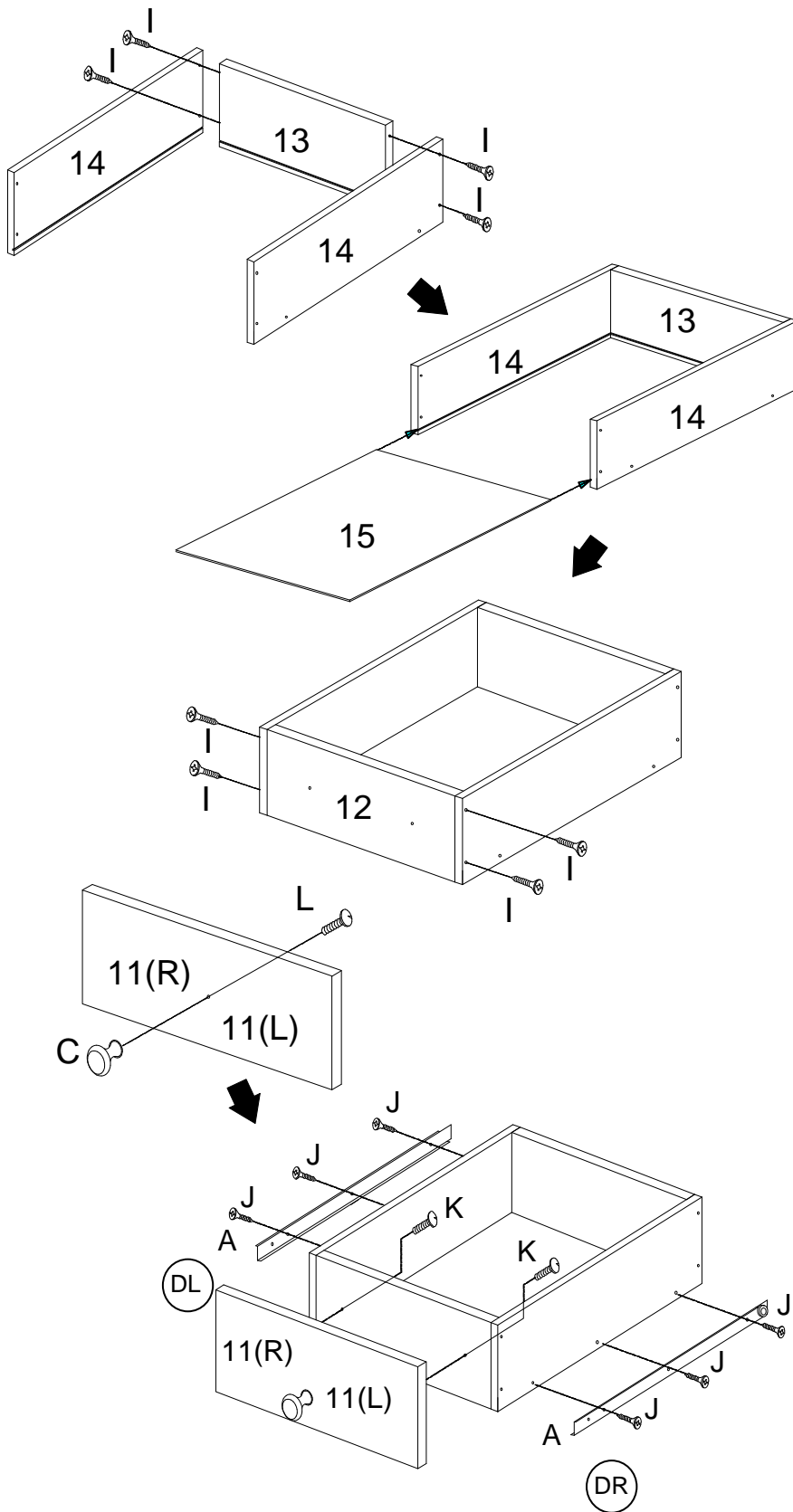

Adjusting the bolts to align drawer outer front panel to fit drawer frame perfectly.

STEP 2

Attach wood dowels (D) with Glue (O) to top board (5) as shown.

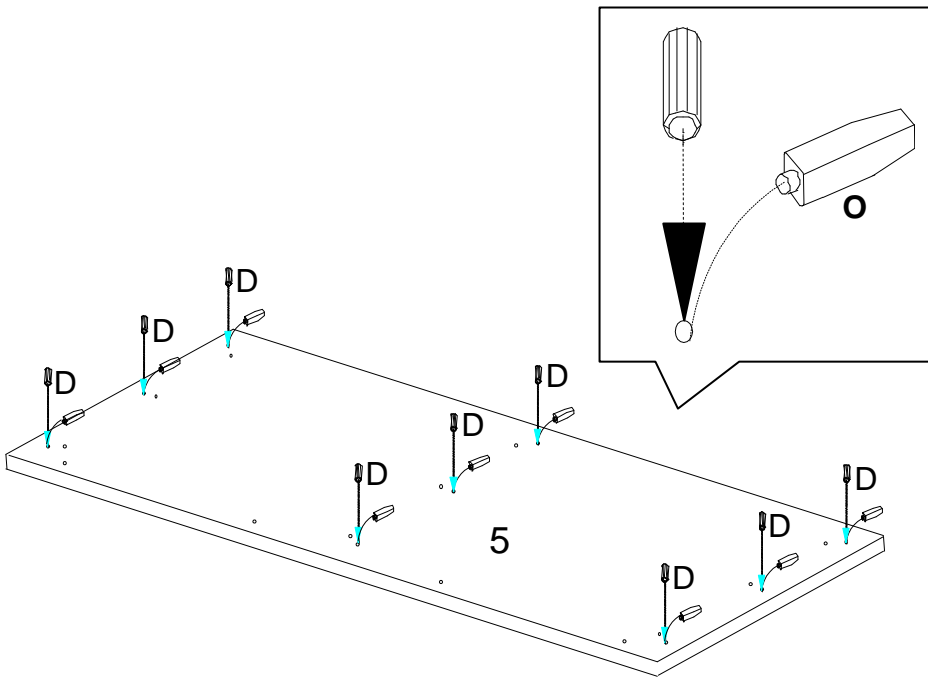

STEP 3

Attach left side panel (7), right side panel (8), and middle panel (9) to top board (5) and secure the panels by wood dowels (D) with glue (O).

Attach wood dowels (D) using glue (O) to panels (7)(8)(9) as shown.

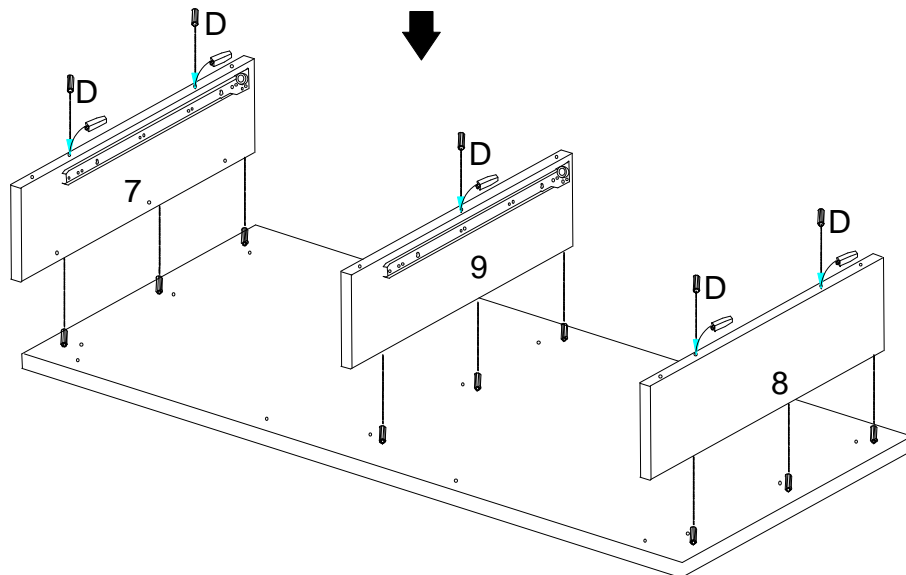

STEP 4

Using wood dowels (D) with glue (O) again to secure back panel (10).

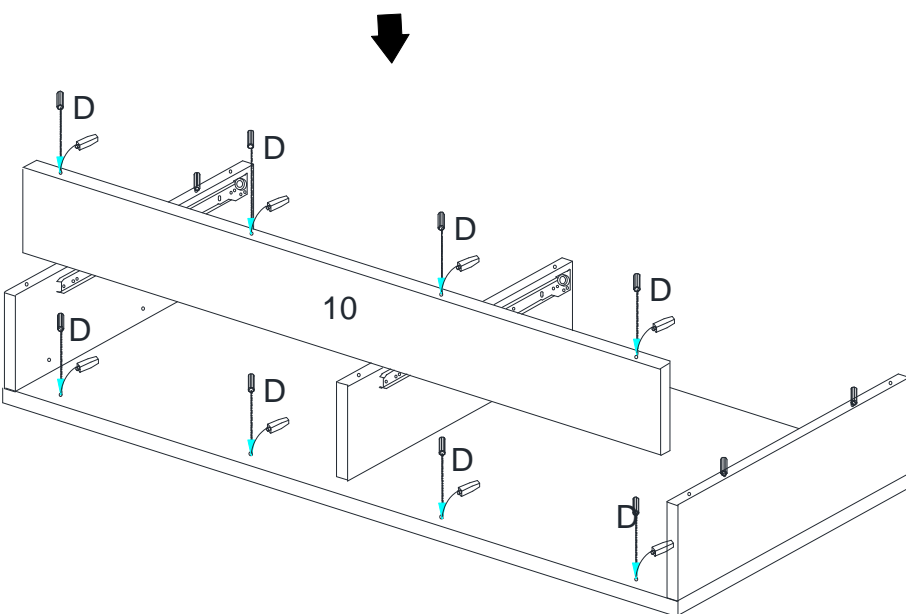

STEP 5

Attach L metal (4) to side panels (7), (8) and (9) using screws (M).

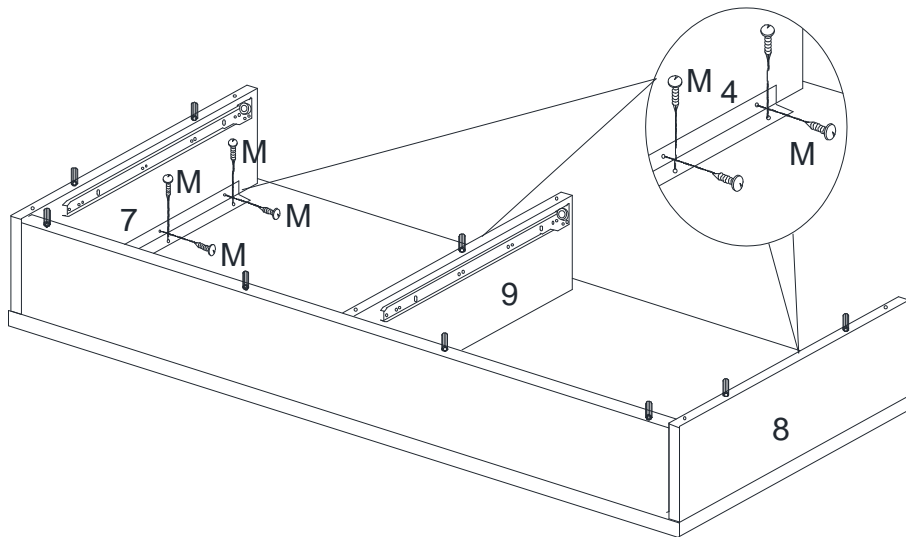

STEP 6

Attach bottom panel (6) to side panels (7), (8) and (9) using screws (H).

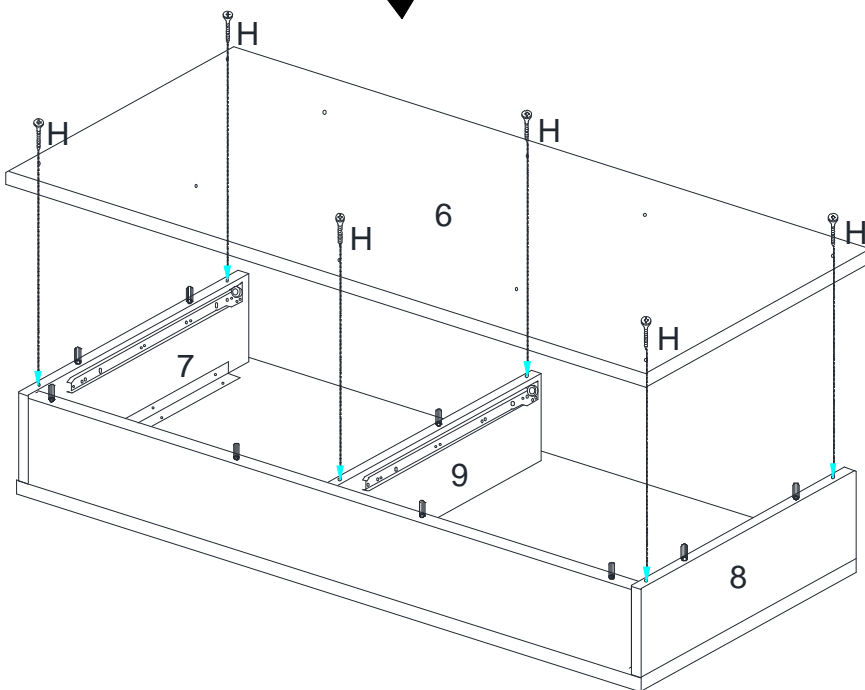

STEP 7

Attach supports (2) to bottom board (6) using bolts (F).

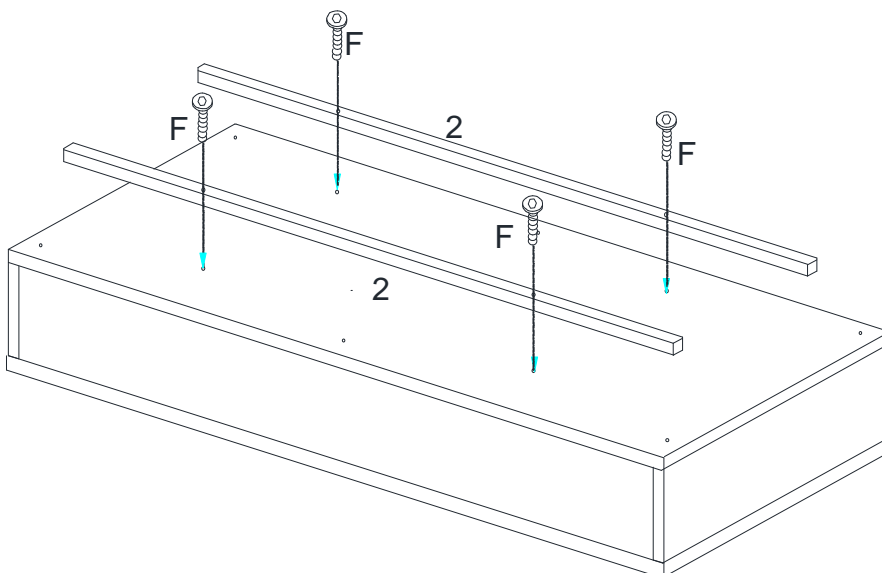

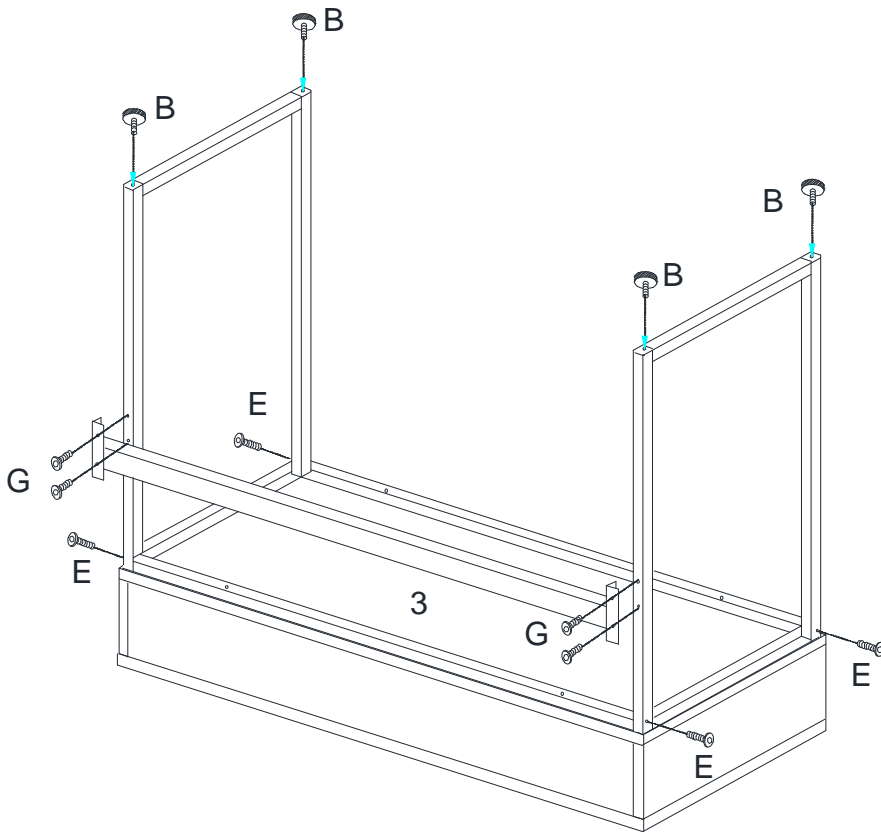

STEP 8

Attach metal side panels (1) to supports (2) using bolts (E), and then, attach stretcher (3) to side panels (1) using bolts (G) as shown.

Attach levelers (B) to the bottom of metal side panels (1).

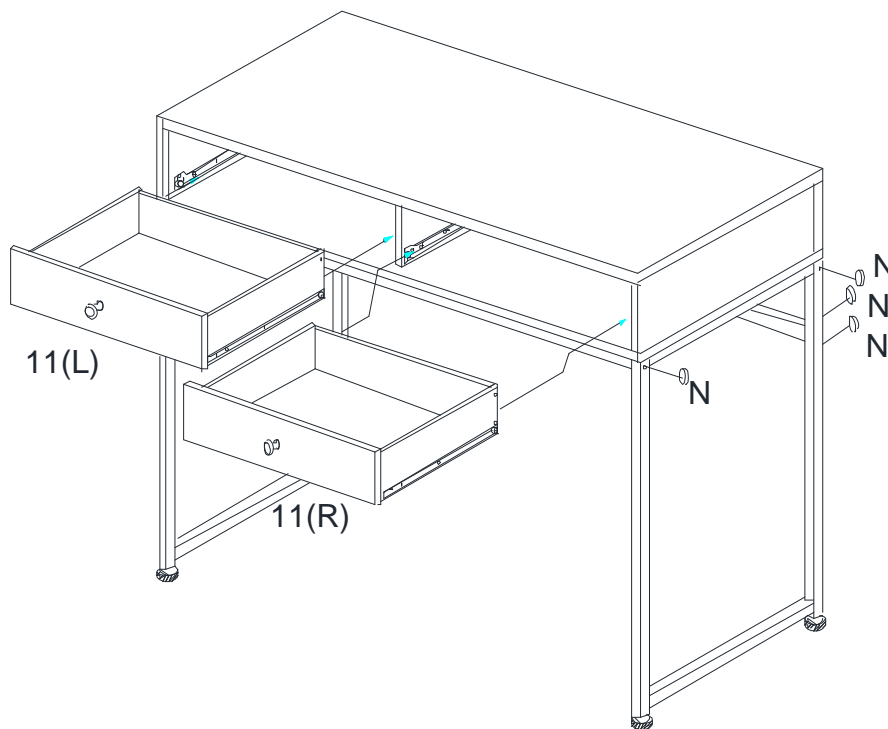

STEP 9

Carefully, turn the assembled unit upright.

Line up the metal glides and insert the assembled right drawer box and left drawer box to the desk drawer frames as shown.

Use caps (N) to cover bolts (E),(G).