

ASSEMBLY INSTRUCTION

Step 1:

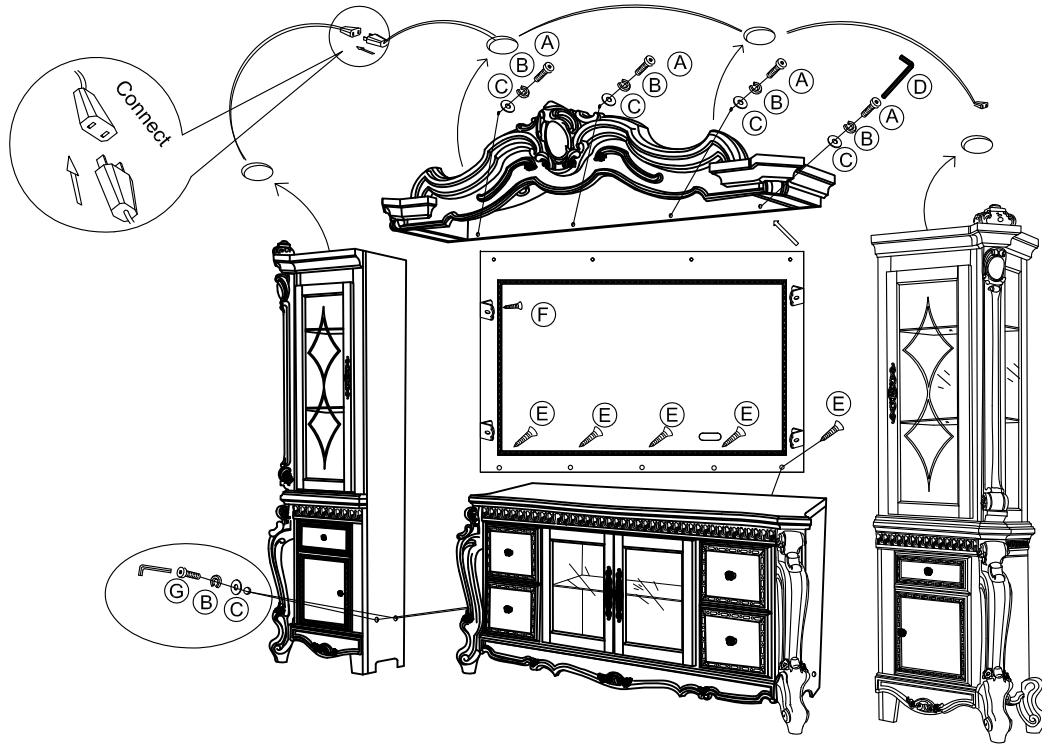

Step 2:

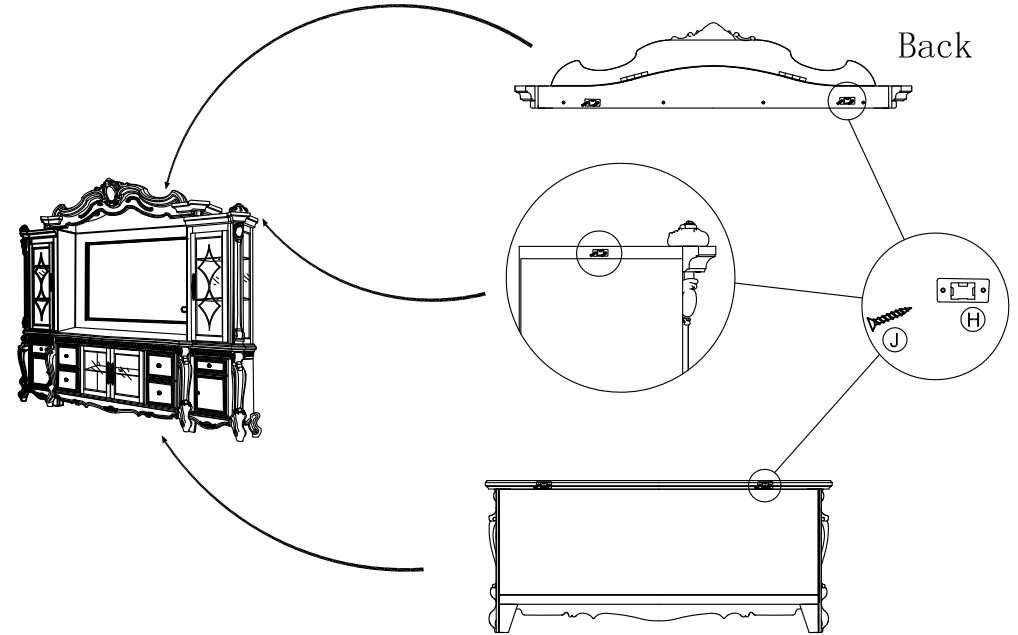

Step 3:

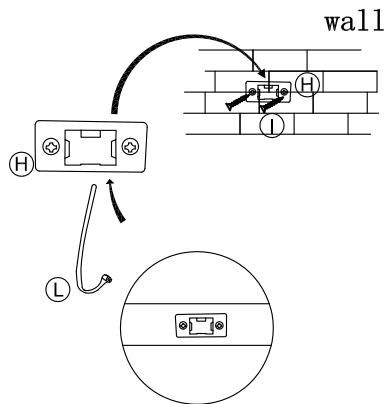

Finish:

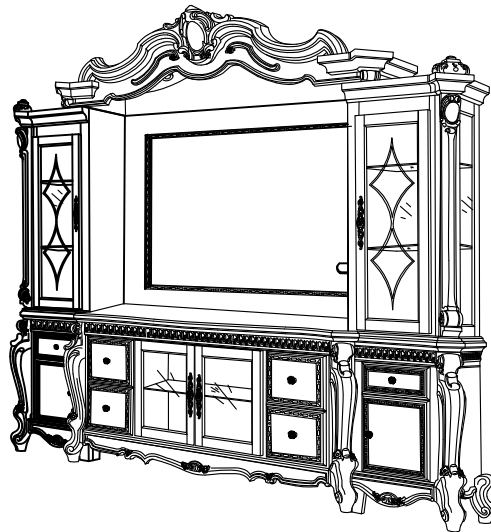

Hardware List

No.:	Description	Drawing	Size	Q' ty
A	Bolt		Ø5/16"X1"	4
B	Lock Washer		Ø5/16"X12mm	8
C	Flat Washer		Ø5/16"X19mm	8
D	Allen Wrench		5mm	1
E	Screw		8X3/4"	5
F	Screw		3*12	8
G	Bolt		Ø5/16"X1-1/2"	4
H	Fasten unit		44mmX20mm	12
I	Screw		Ø7mmX38mm	12
J	Screw		Ø6mmX16mm	12
K	Shrink bolt		Ø5/16"X1-1/2"	12
L	Safety belt		8mmX250mm	6