

ASSEMBLY INSTRUCTIONS

MODEL: MUSES TABLE

ITEM #
74640T / 74641ST

Please read instructions carefully

Remove all wrapping materials, staples and packing straps from the carton. Refer to Parts List and Hardware List and ensure they are complete before you start assembling. Place all wooden parts on a clean, flat and soft surface (e.g carpet or rug) to prevent parts from being scratched.

- CAUTIONS: 1) DO NOT FULLY TIGHTEN BOLTS AND NUTS UNTIL ALL PARTS HAVE BEEN ASSEMBLED.
 2) DO NOT OVER-TIGHTEN BOLTS AND NUTS UNTIL ALL PARTS HAVE BEEN ASSEMBLED.
 3) KEEP ALL HARDWARE PARTS OUT OF REACH OF CHILDREN.

PARTS LIST (FOR 1 NOS. OF TABLE)

NO.	COMPONENT	QTY.
P1	TABLE TOP	1
P2	PEDESTAL LEG	1
P3	LEG PRONG	4
P4	MOUNTING PLATE	1

HARDWARE LIST (FOR 1 NOS. OF TABLE)

NO.	DESCRIPTION	QTY.
H1	WRENCH	1
H2	HEX NUT	8
H3	SPRING WASHER M8	8
H4	FLAT WASHER M8	8
H5	JCBC BOLT M6 x 35mm	4
H6	SPRING WASHER M6	4
H7	SCREW M4 X 32mm	8
H8	ALLEN KEY	1

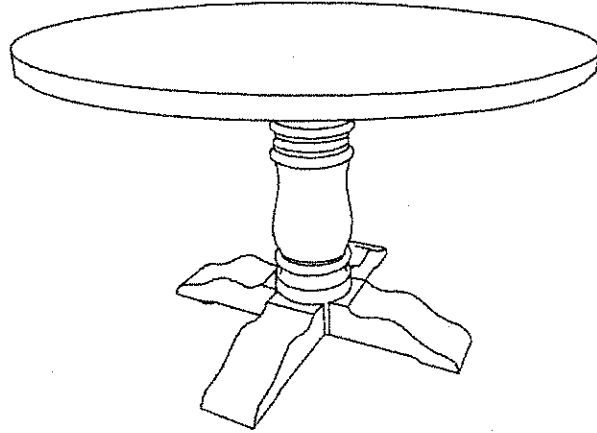

COMPLETE ASSEMBLY

STEP 1

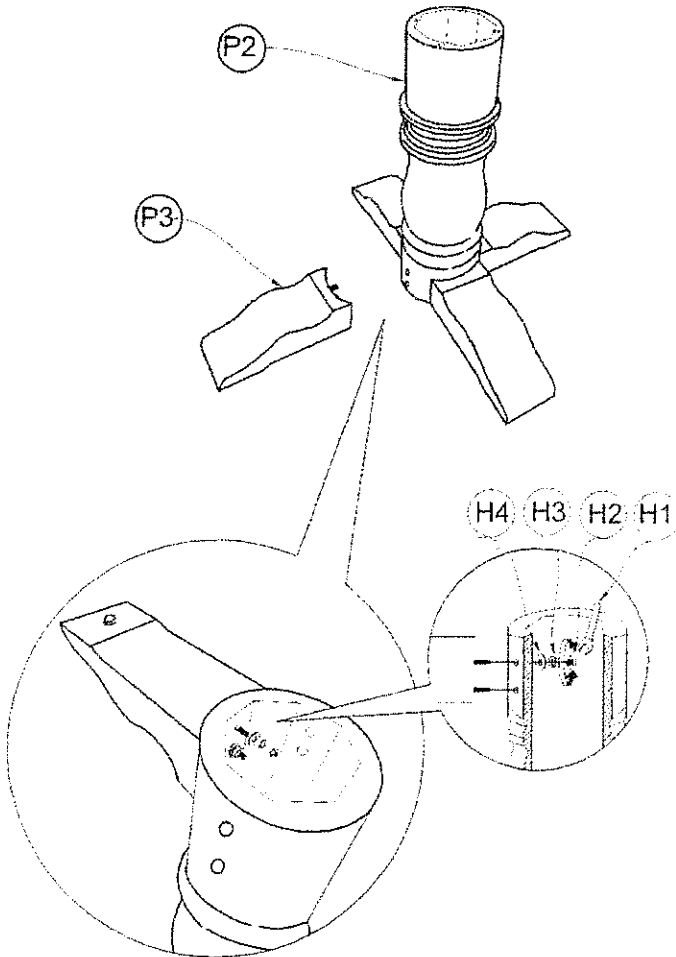

STEP 2

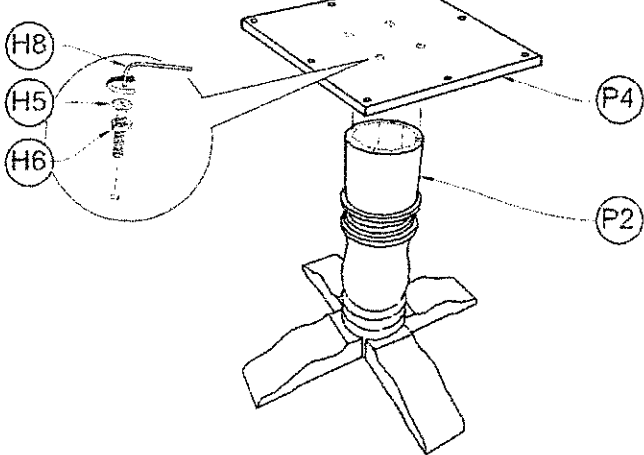

STEP 3

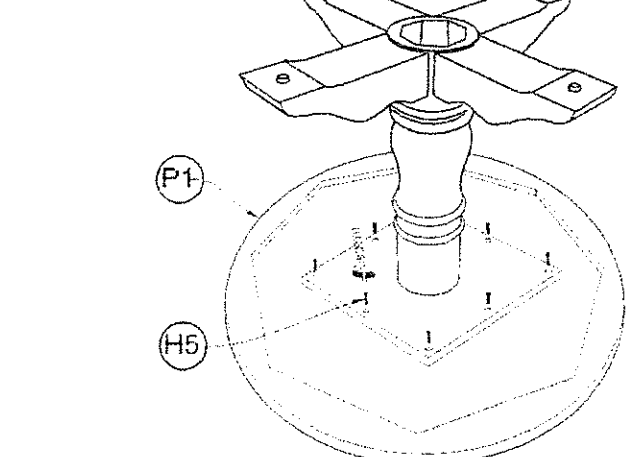

CARE AND MAINTENANCE

- SAFETY** - To avoid any risk of suffocation to children and animals, dispose off plastic bags immediately.
CLEANING - Clean with damp cloth and mild detergent. Do not use bleach or abrasive products.
FITTINGS - Tighten bolts and nuts from time to time to ensure all parts of product are securely fitted.