









ASSEMBLY INSTRUCTION

Side/Arm Chair

Thank you for purchasing this quality product. Be sure to check all packing material carefully for small parts which may have come loose inside the carton during shipment. Identify and count all parts and compare with the parts list below.

****Assemble the chair on a flat surface such as a carpet or cloth to prevent scratching the chair finish. Read all instruction and study the drawings carefully before starting the assembly process.**

Hardware list				Side Chair	Arm Chair
A	Allen Bolt		Ø5/16**3"	4pcs	4pcs
B	Allen Bolt		Ø5/16**2"	4pcs	4pcs
C	Allen Bolt		Ø5/16**1-3/4"	—	2pcs
D	Allen Bolt		Ø5/16**1-1/2"	1pc	1pc
E	Lock Washer		Ø5/16"	9pcs	11pcs
F	Flat Washer		Ø5/16**19mm	9pcs	11pcs
J	Allen Wrench		5MM	1pc	1pc
H	Dowel		Ø10*30mm	2pcs	4pcs
I	Screw		#8*1-1/4"	—	2pcs

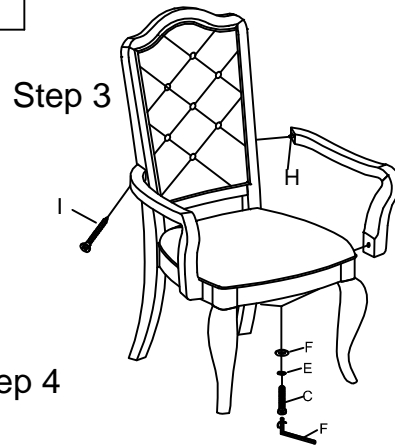
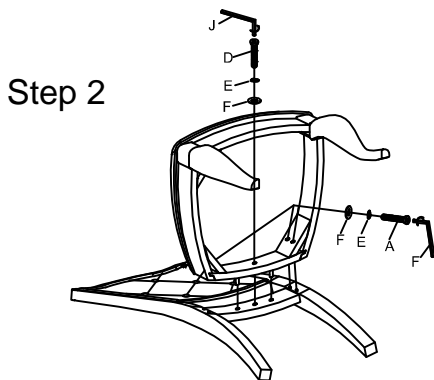
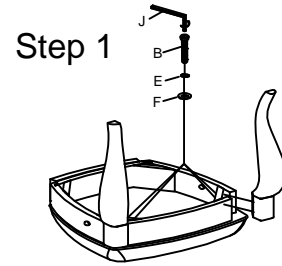

Step 4

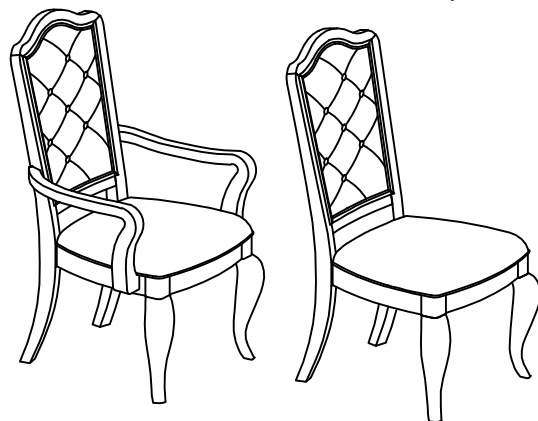

Step1: Assemble the front legs to the seat frame.

Step2: Assemble the seat frame to the chair back.

Step3: Assemble the chair arms to the chair back and the seat frame (arm chair only).

****Note:** Do not tighten all the bolts and the screws until the chair has been put on a flat surface to adjust & level all the legs so that they do not wobble. Once adjusted then tighten all the bolts and the screws but not over-tighten the bolts and the screws.

MADE IN CHINA