

# Assembly Instructions

## Loft Bed

### **SAFETY WARNING**



1. Follow the information on the warnings appearing on the upper bunk end structure and on the carton. Do not remove warning label from bed.
2. Always use the recommended size mattress or mattress support, or both, to help prevent the likelihood of entrapment or falls.
3. Surface of mattress must be at least 5 in. (127 mm) below the upper edge of guardrails.
4. Do not allow children under 6 years of age to use the upper bunk.
5. Periodically check and ensure that the guardrail, ladder, and other components are in their proper position, free from damage, and that all connectors are tight.
6. Do not allow horseplay on or under the bed and prohibit jumping on the bed.
7. Prohibit more than one person on upper bunk.
8. Always use the ladder for entering and leaving the upper bunk.
9. Do not use substitute parts. Contact the manufacturer or dealer for replacement parts.
10. Use of a night light may provide added safety precaution for a child using the upper bunk.
11. Always use guardrails on both long sides of the upper bunk. If the bunk bed will be placed next to the wall, the guardrail that runs the full length of the bed should be placed against the wall to prevent entrapment between the bed and wall.
12. The use of water or sleep flotation mattresses is prohibited.
13. **STRANGULATION HAZARD**—Never attach or hang items to any part of the bunk bed that are not designed for use with the bed; for example, but not limited to hooks, belts and jump ropes.
14. Keep these instructions for future reference.

### **SIZE OF MATTRESS AND FOUNDATION:**

Use only mattress, which is 37 1/2" - 38 1/2" width and 74"-75" long on upper bunk (twin size.) Ensure that the thickness of the mattress does not exceed 7" and that the mattress surface is at least 5" (127mm) below upper edge of guardrails.

### **WARNING:**

Adult Assembly Required. This package contains small parts. Keep away from children.

### **Replacement Part :**

Replacement part, including additional guardrails may be obtained from any ACME FURNITURE, INC Dealer.

### **DISTRIBUTED BY :**

ACME FURNITURE, INC.  
18895 E.Arenth Ave City of Industry,  
CA91748.

# ASSEMBLY INSTRUCTIONS FOR ACME FURNITURE

## MODEL #37990

Thank you for purchasing the quality product. Be sure to check all packing material carefully for small parts which may have come loose inside the carton during shipment. Separate, identify and count all parts and metal hardware. Compare with all part list to be sure all part are present. If any part(s) are missing or damage, please contact your local furniture dealer. For efficient and speedy service, please indicate the model number and code letter of part(s) needed.

\*\*\*Do not fully tighten screws until fully assembled\*\*\*

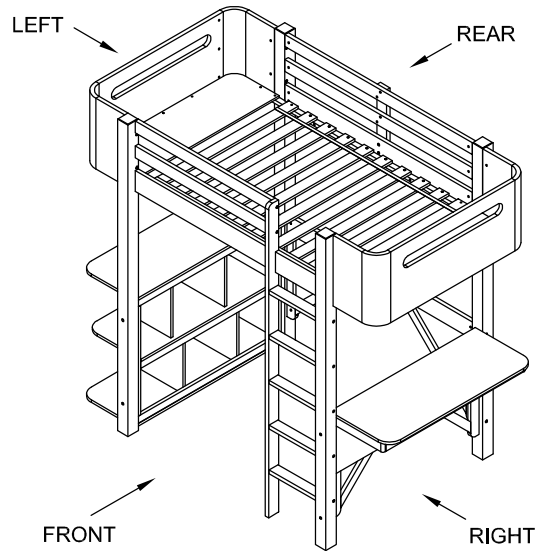

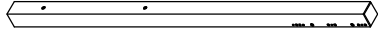
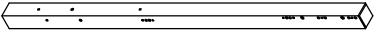
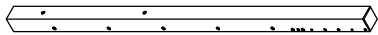
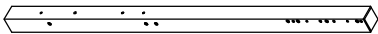
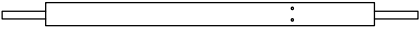
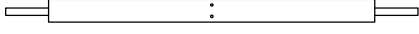
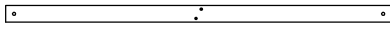
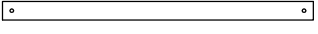
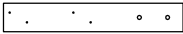

### COMPONENT PARTS

DESCRIPTION	PART NAME	Q'TY (PCS)
(A)	LEG (LEFT - FRONT) 	1
(B)	LEG (LEFT - REAR) 	1
(C)	LEG (RIGHT- FRONT) 	1
(D)	LEG (RIGHT - REAR) 	1
(E)	FRONT SIDE RAIL 	1
(F)	REAR SIDE RAIL 	1
(G)	REAR GUARD RAIL 	2
(H)	FRONT GUARD RAIL 	2
(I)	GUARD RAIL SUPPORT 	1

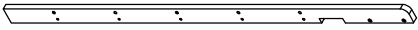
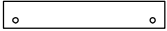
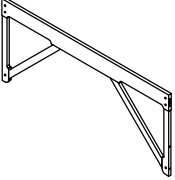
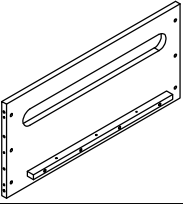
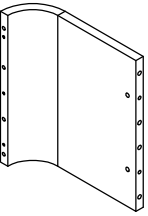
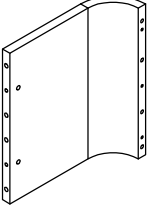
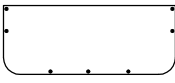
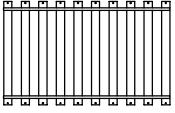
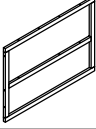
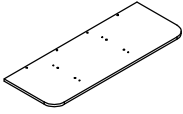
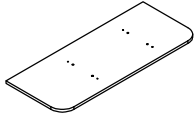



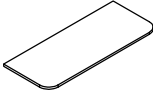

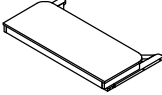





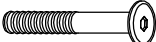

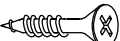
## COMPONENT PARTS

DESCRIPTION	PART NAME	Q'TY (PCS)
(J)	LADDER RAIL 	1
(K)	LADDER STRETCHER 	5
(L)	LOWER FRAME 	1
(M)	HEADBOARD / FOOTBOARD PANEL 	2
(N)	HEADBOARD / FOOTBOARD SIDE PANEL (LEFT REAR & RIGHT FRONT) 	2
(O)	HEADBOARD / FOOTBOARD SIDE PANEL (LEFT FRONT & RIGHT REAR) 	2
(P)	PANEL SLAT 	2
(Q)	SLAT 	1
(R)	FRAME (SHELF) 	1
(S)	LOWER PANEL (SHELF) 	1
(T)	CENTER PANEL (SHELF) 	1

## COMPONENT PARTS

DESCRIPTION	PART NAME	Q'TY (PCS)
(U)	UPPER PANEL (SHELF) 	1
(V)	DIVIDER PANEL 	4
(W)	TABLE 	1

## HARDWARE REQUIRED

DESCRIPTION	HARDWARE	Q'TY (PCS)
(1)	JCBC M6 x 100mm 	37
(2)	JCBC M6 x 90mm 	4
(3)	JCBC M6 x 60mm 	7
(4)	JCBC M6 x 30mm 	4
(5)	JCBC-W M6 x 30mm 	18
(6)	WOOD SCREW M4.0 x 30mm 	20
(7)	MINIFIX CAM Ø15 x 12mm 	28
(8)	MINIFIX BOLT 32mm 	28
(9)	BARREL NUT M6 x 13mm 	44
(10)	WOOD DOWEL Ø8 x 30mm 	28
(11)	WOOD DOWEL Ø10 x 30mm 	78
(12)	ALLEN KEY M4 	1
(13)	METAL PLATE 	2
(14)	PAN HEAD SCREW M3.5 x 16mm 	8
(15)	PAN HEAD SCREW M4.0 x 38mm 	4

### Attention :

\*\*\* Some number part listed on the instruction sheet may not be in parts bag as they may already be assembled. Carefully check parts and packing materials prior to ordering replacements.

# How to assemble :

## STEP 1 :

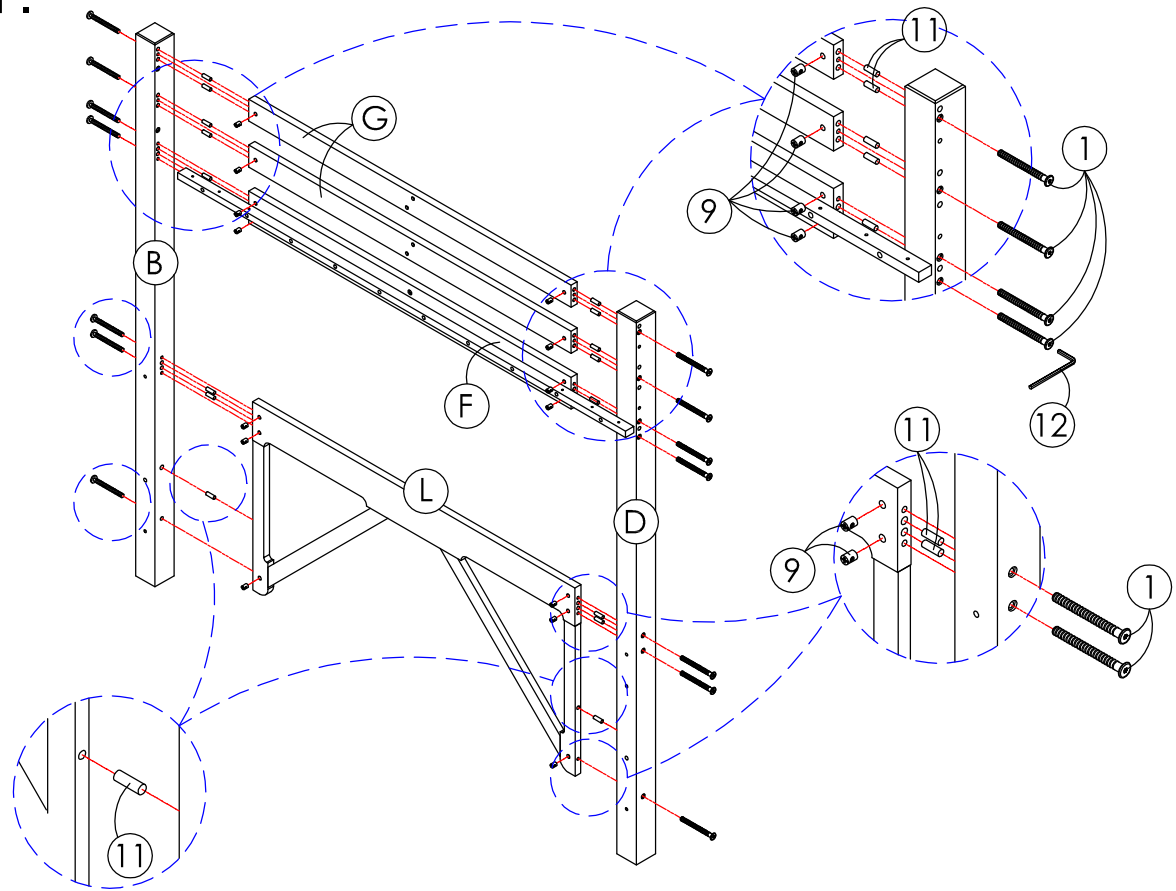

## STEP 2 :

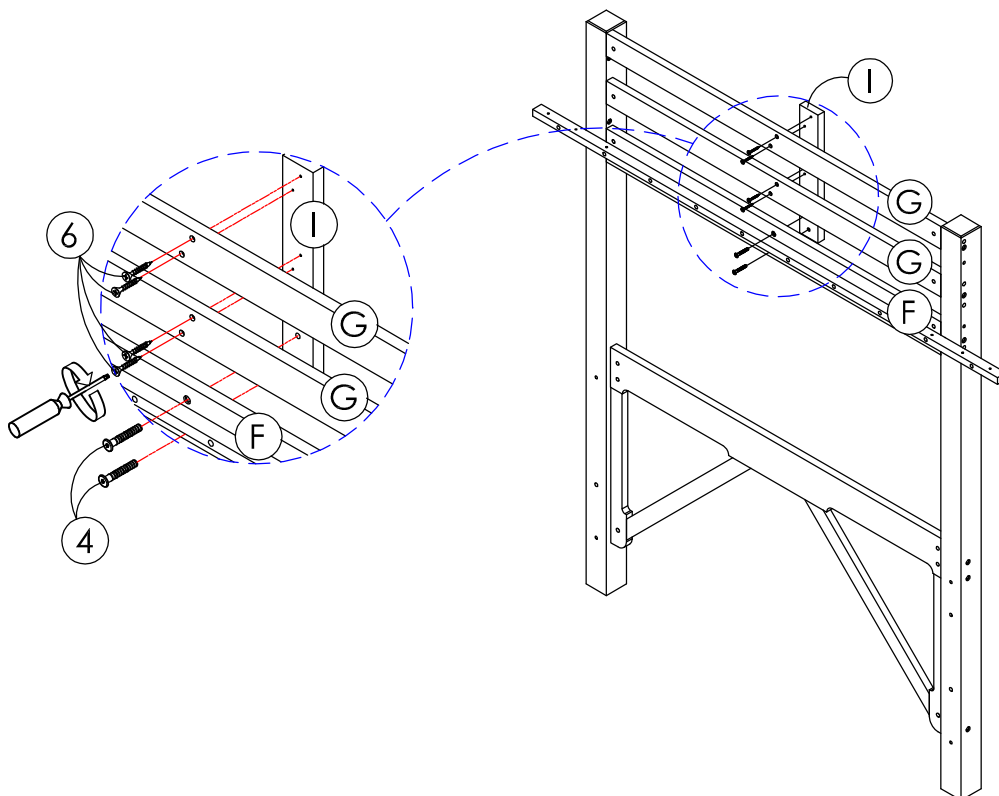

### STEP 3 :

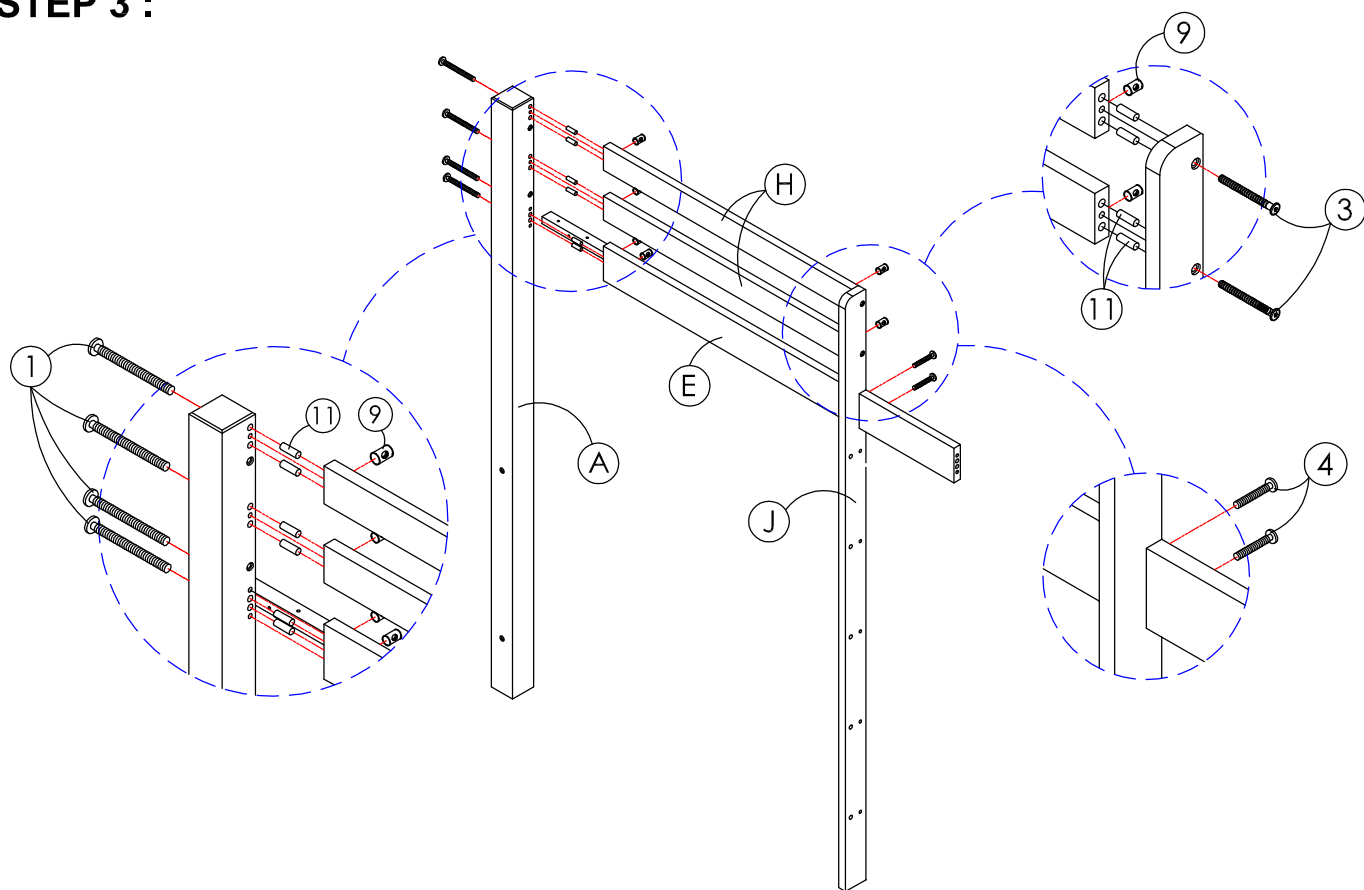

### STEP 4 :

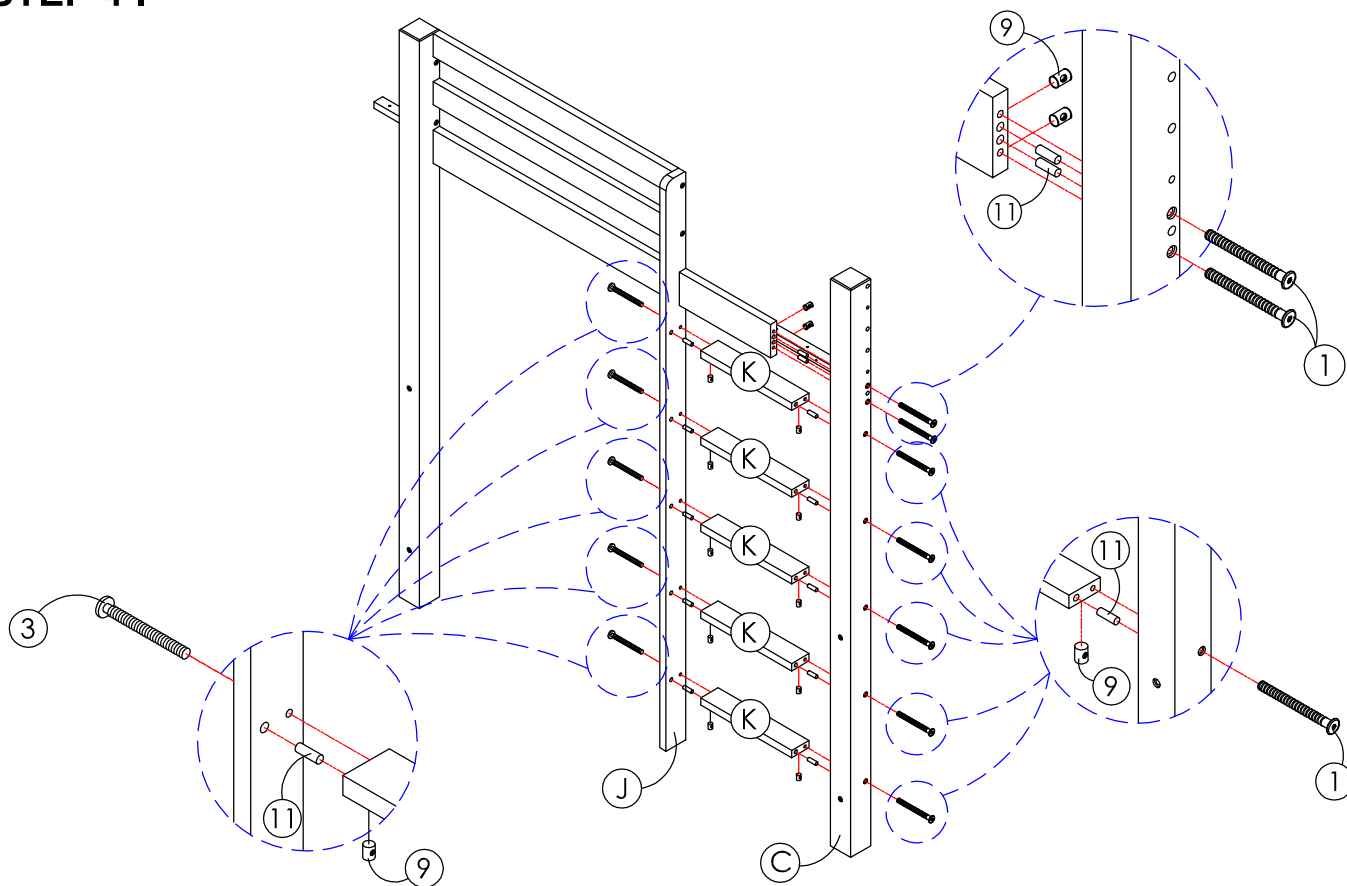

**STEP 5 :**

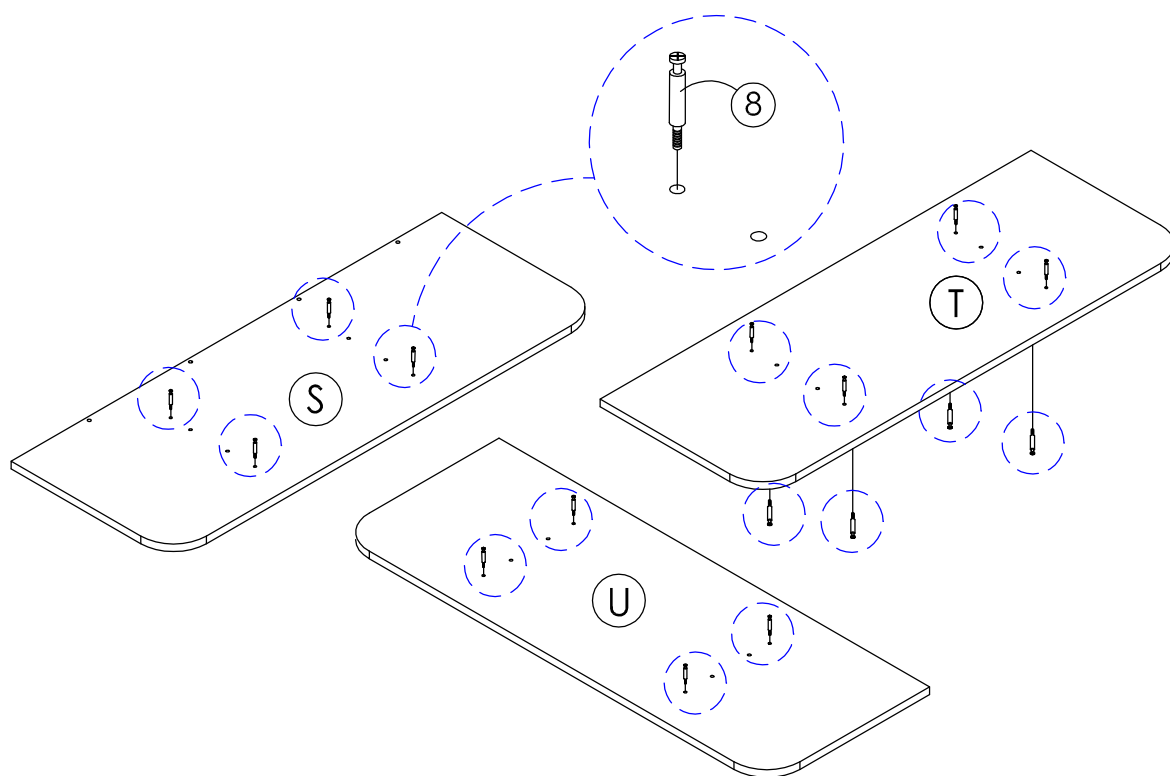

**STEP 6 :**

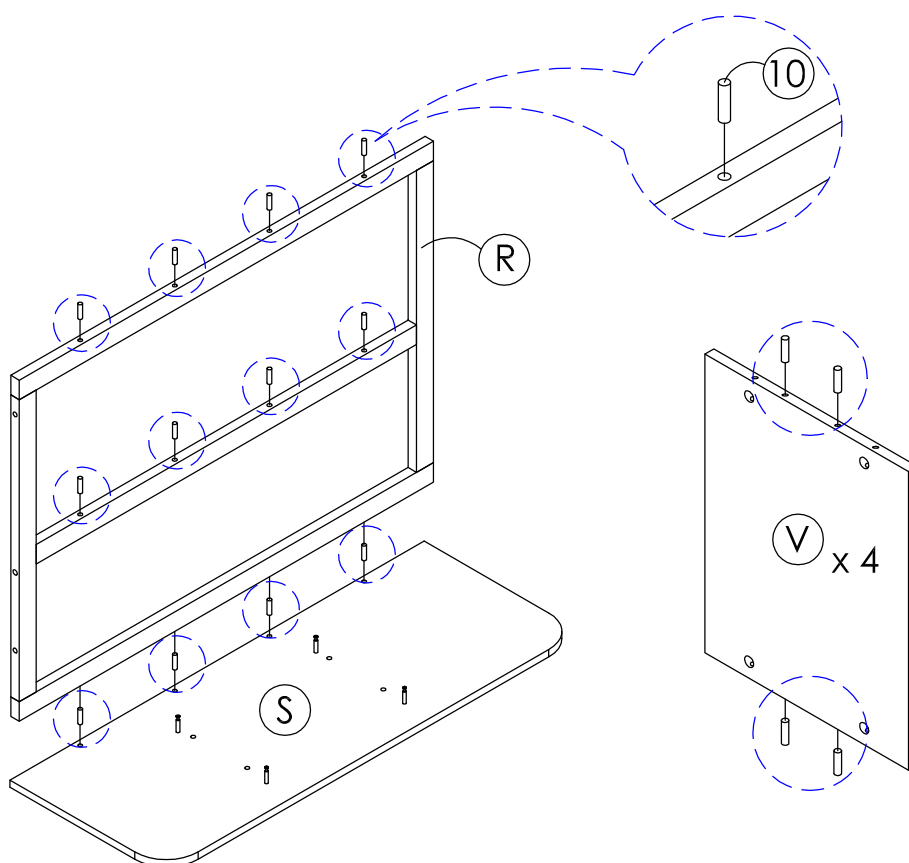

**STEP 7 :**

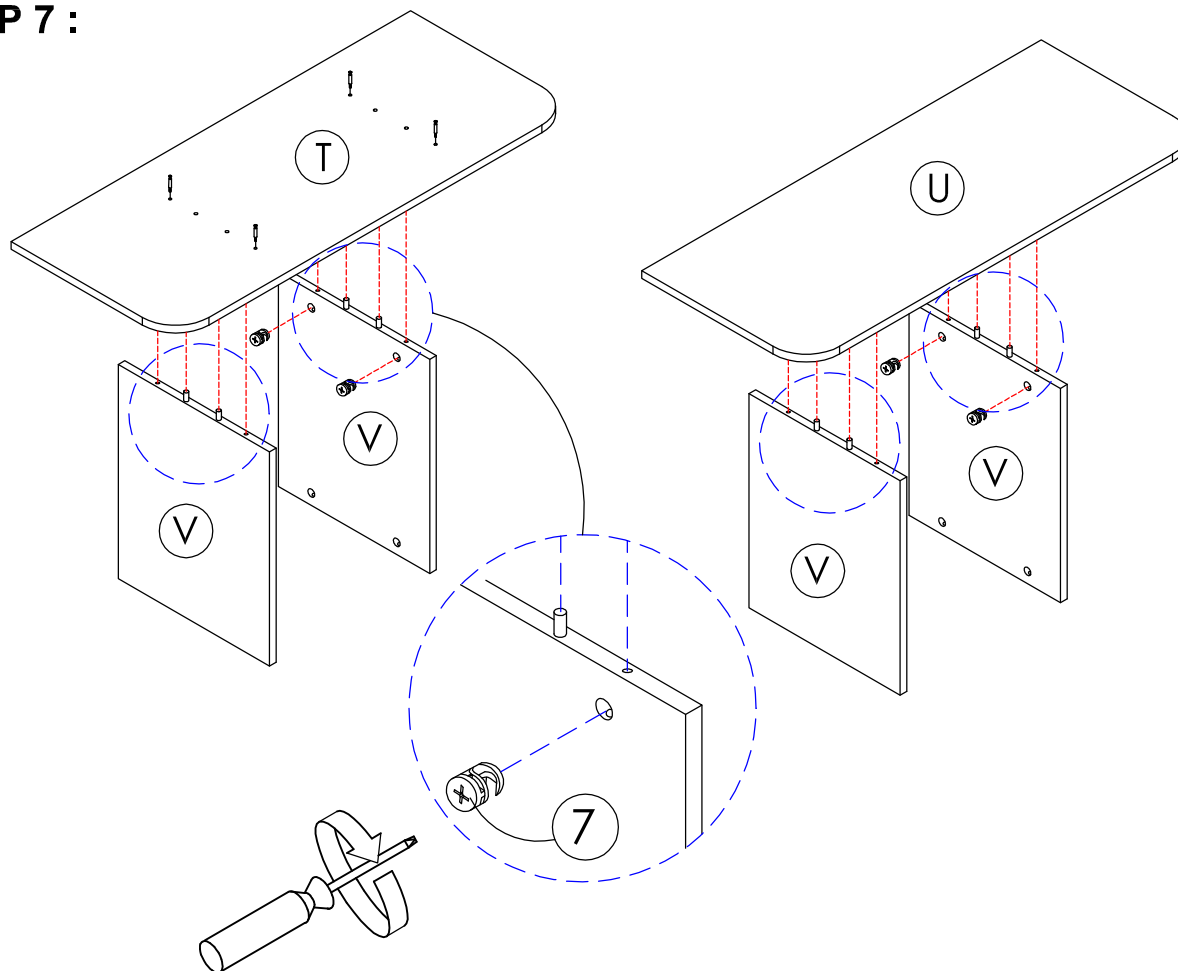

**STEP 8 :**

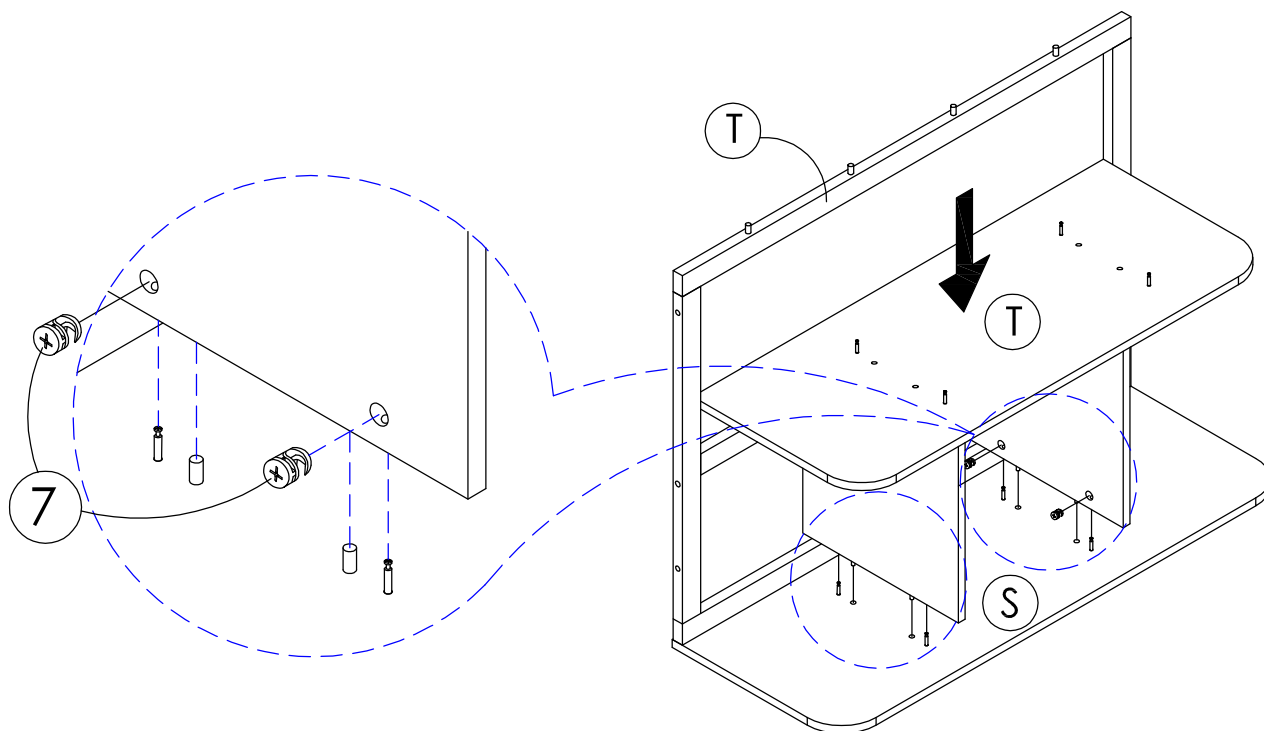



**STEP 9 :**

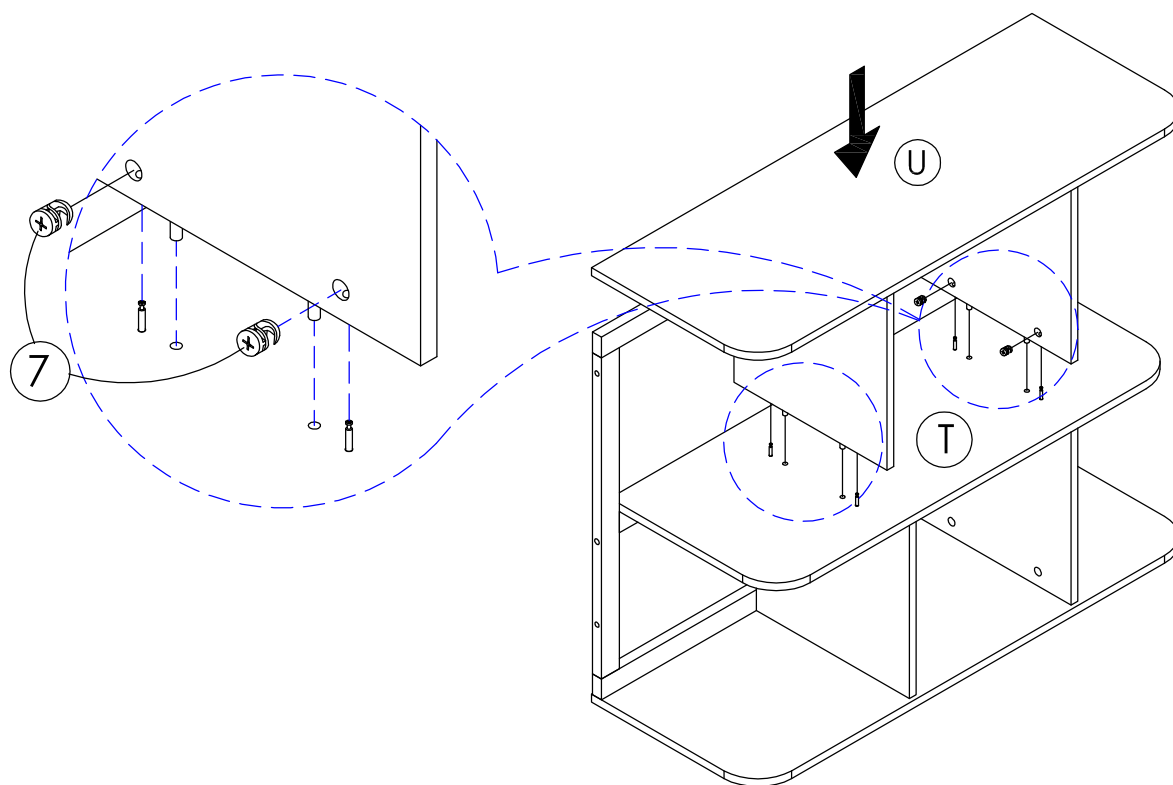

**STEP 10 :**

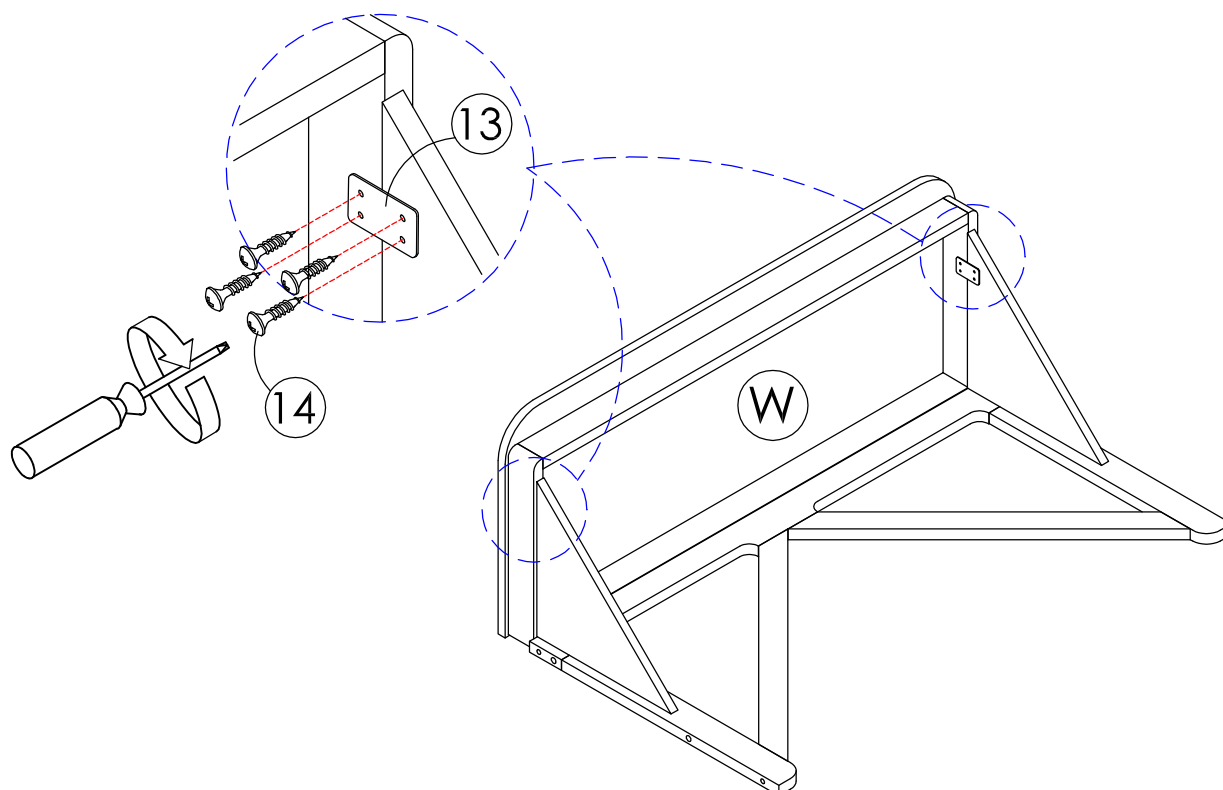

**STEP 11 :**

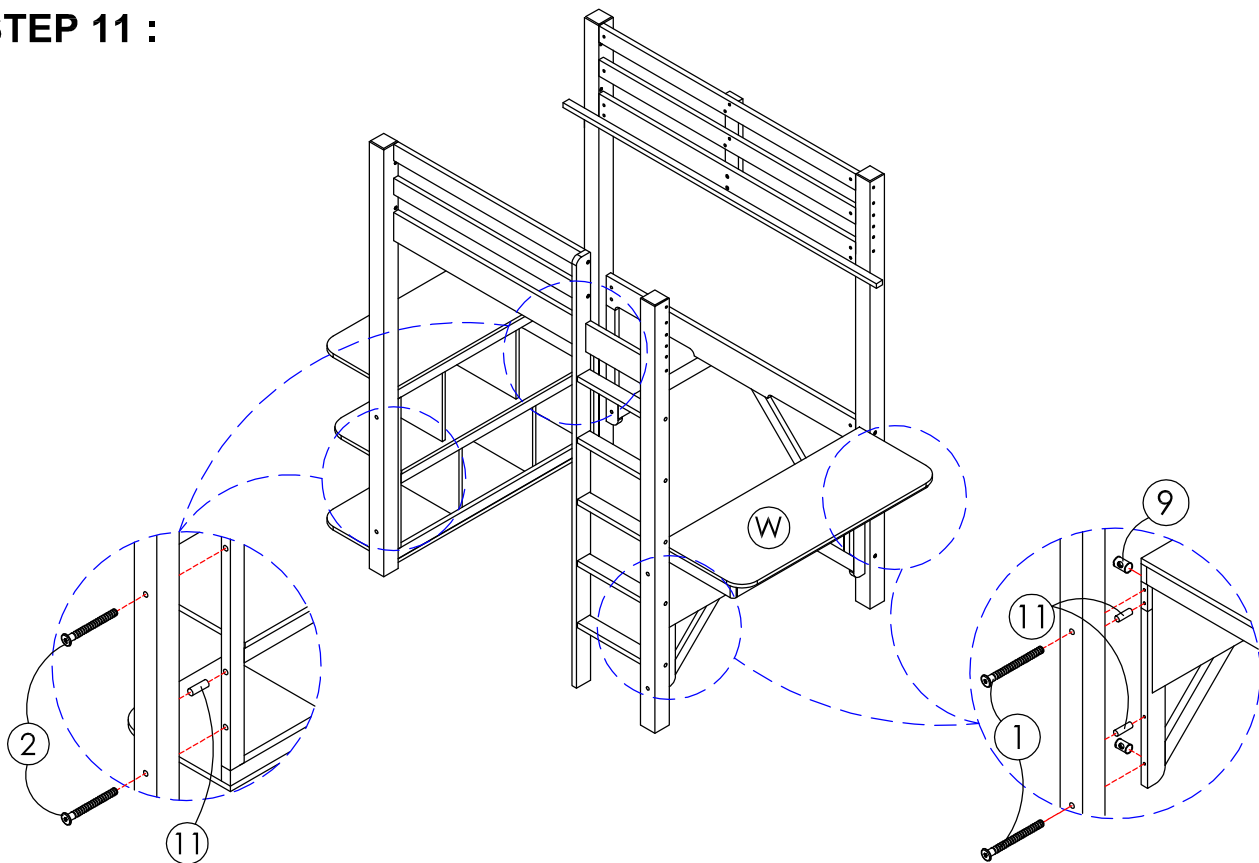

**STEP 12 :**

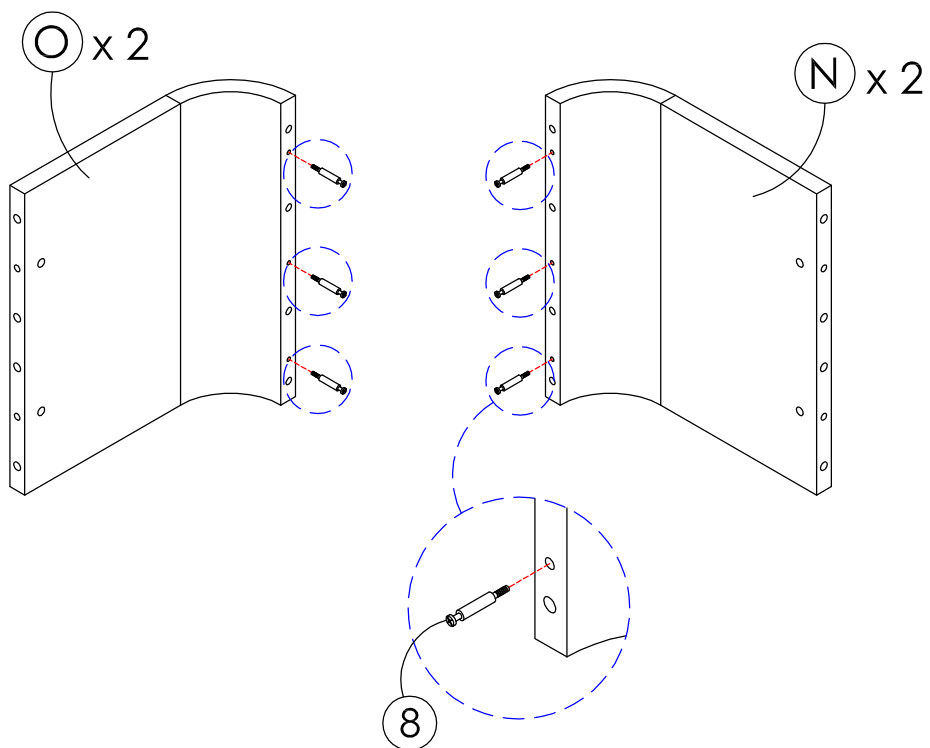

**STEP 13 :**

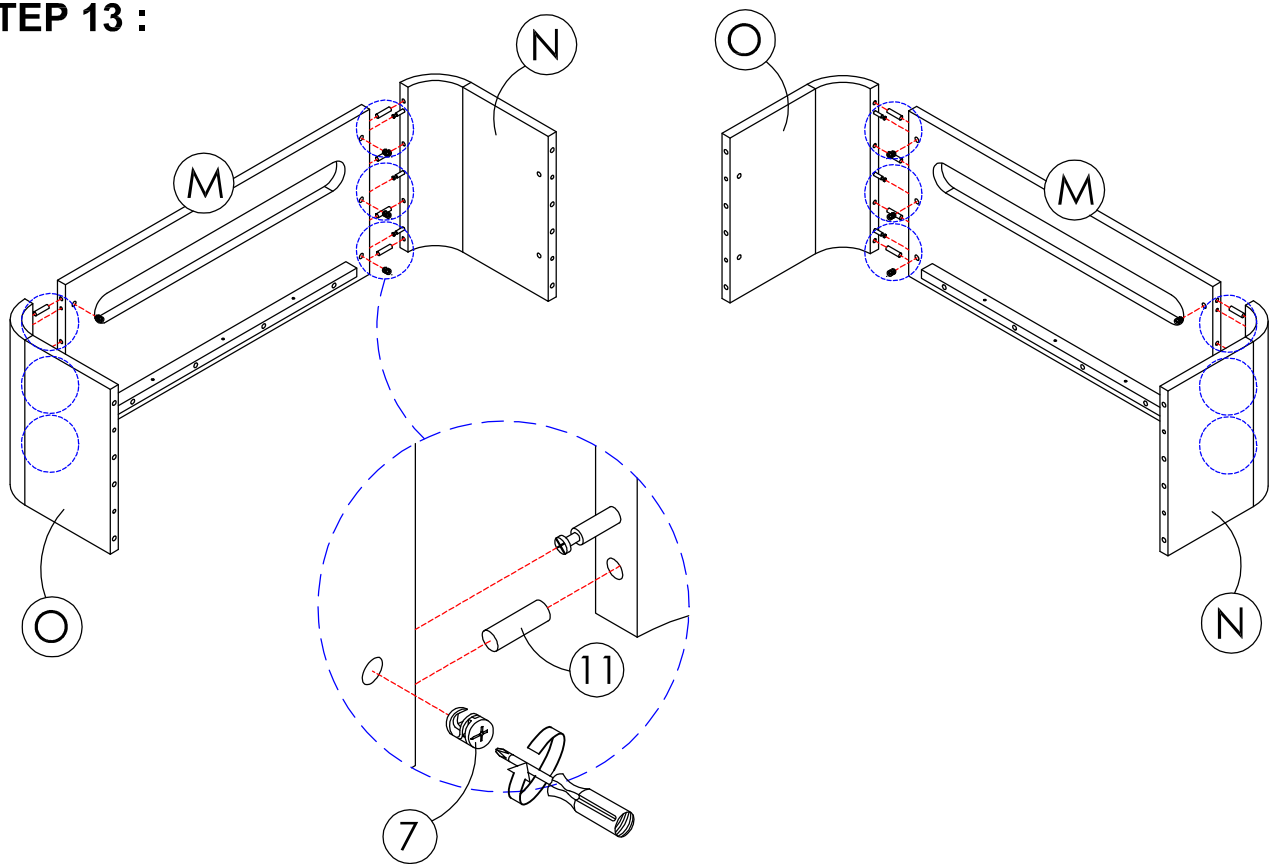

**STEP 14 :**

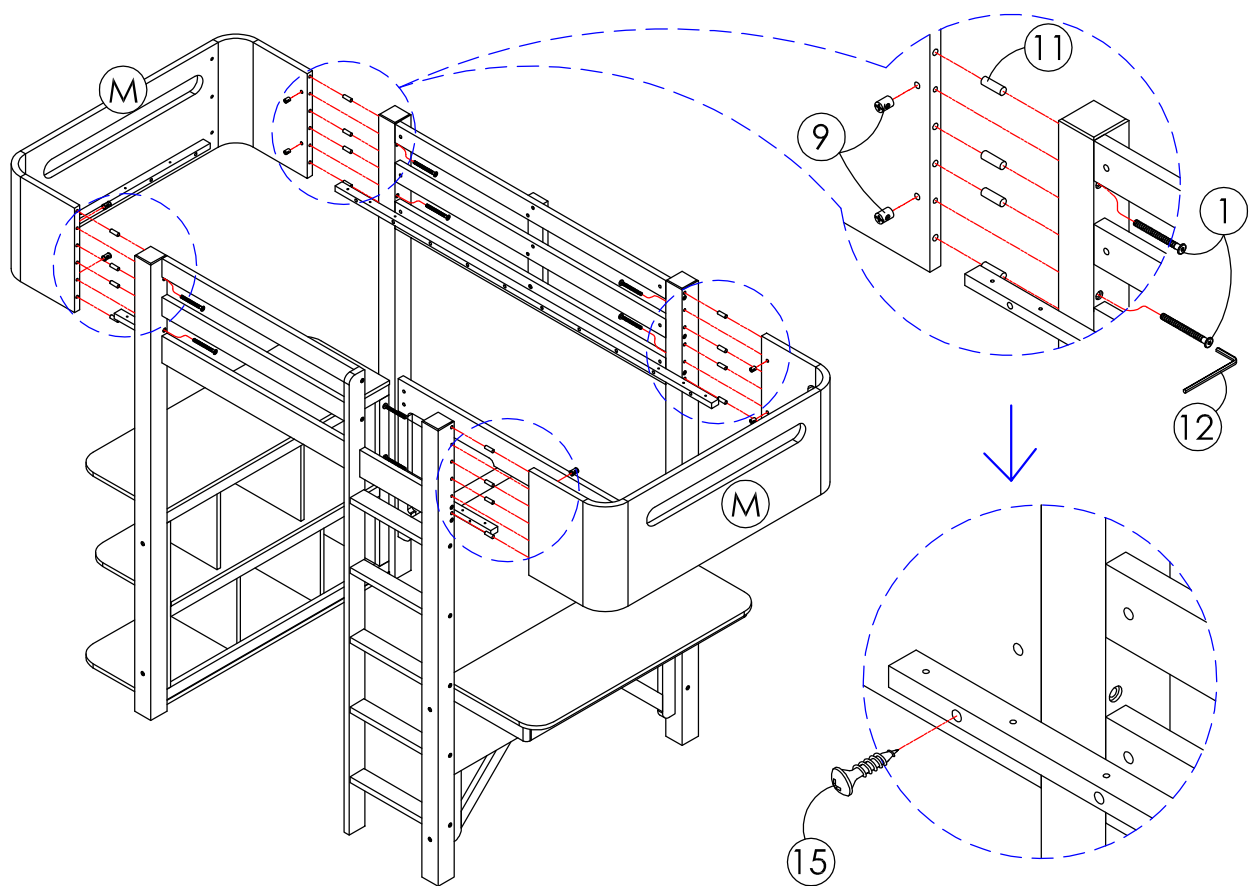

**STEP 15 :**

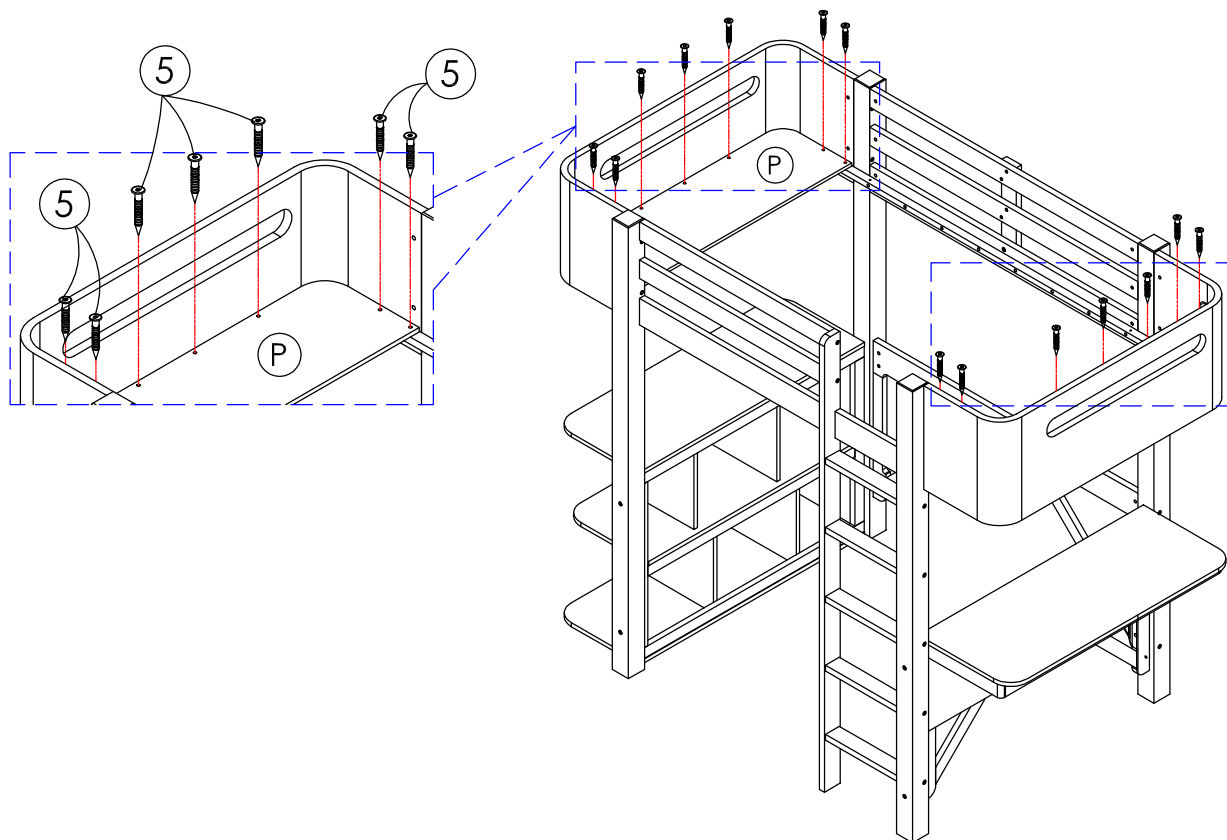

**STEP 16 :**

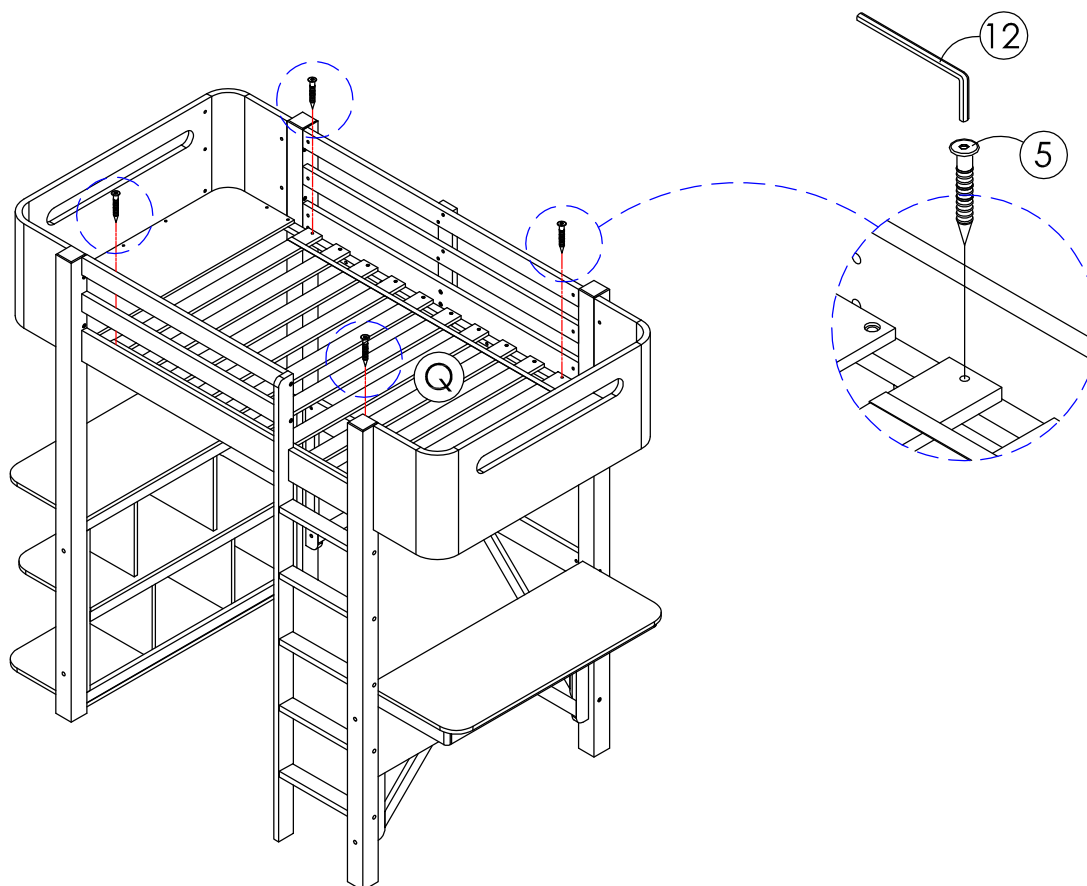

## STEP 17

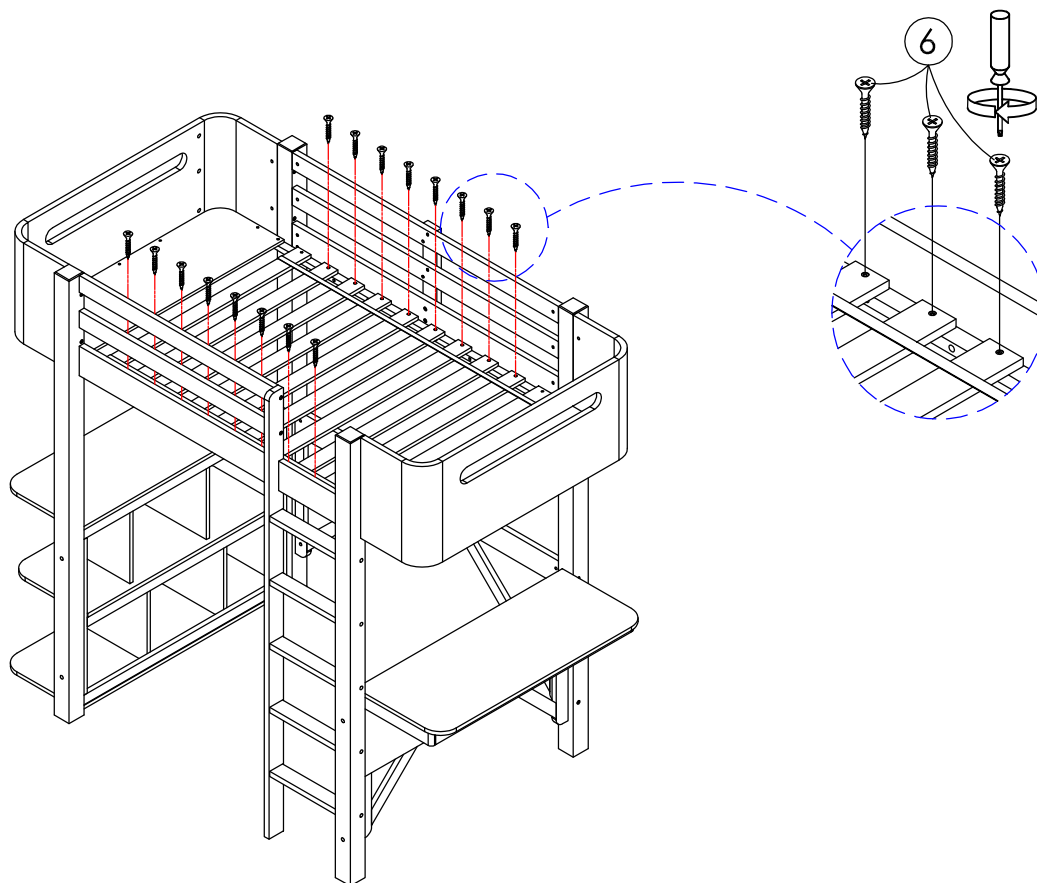

## COMPLETE ASSEMBLY

