

# ASSEMBLY INSTRUCTIONS

ITEM NO.:37562

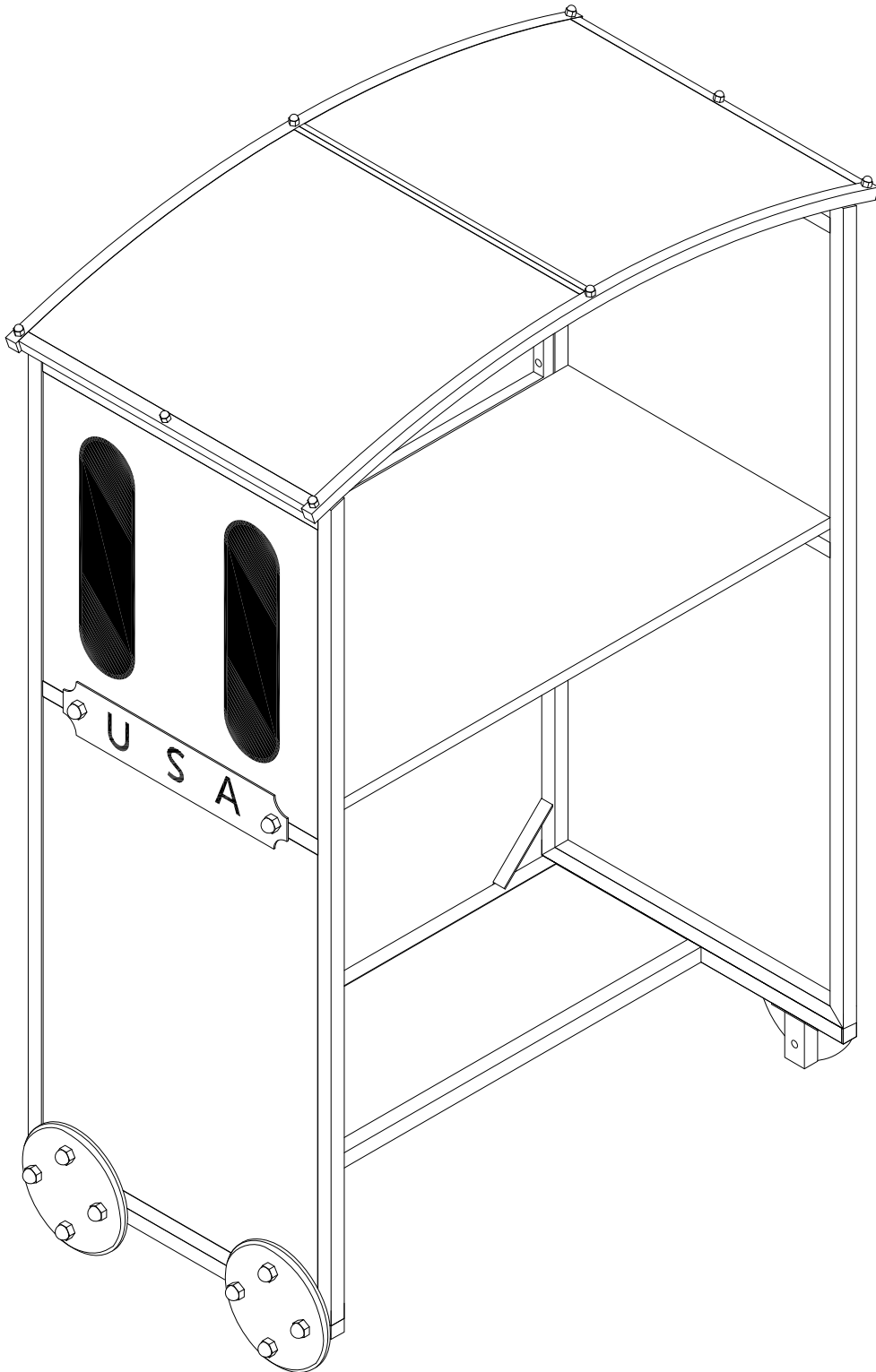

Do not tighten screws until completely assembled.

# PARTS IDENTIFICATION

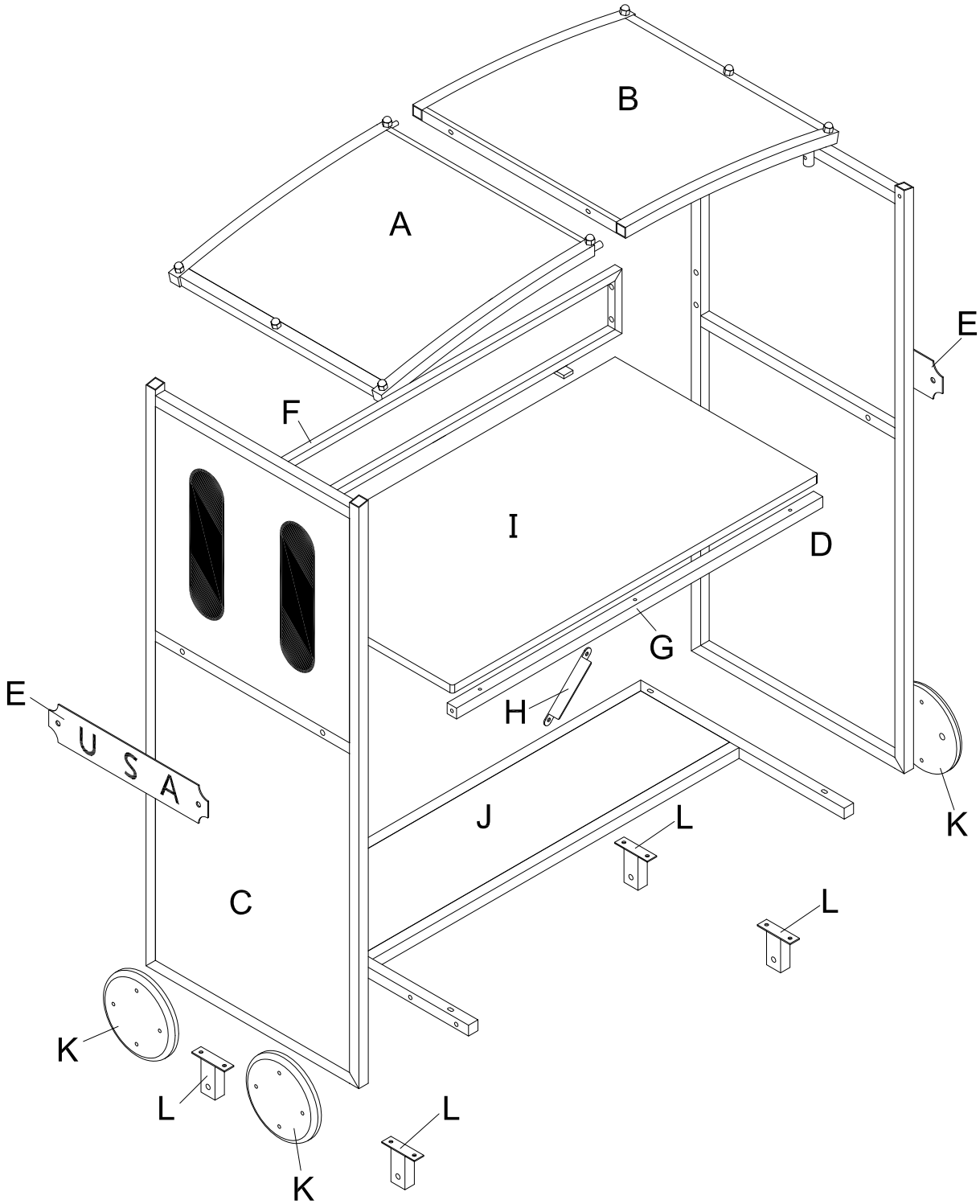

# PARTS IDENTIFICATION

A		1pc		F		1pc
B		1pc		G		1pc
C		1pc		H		2pcs
D		1pc		I		1pc
E		2pcs		J		1pc
				K		4pcs
				L		4pcs

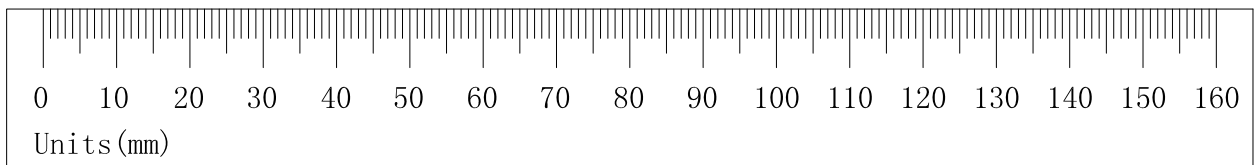

# HARDWARE LIST

1 M6x35 4pcs	2 M6x30 4pcs	3 M6x15 18pcs
4 M6x60 2pcs	5 M6x25 2pcs	6 17x17x18 RED 16pcs
7 4x4 2pcs	8 M6x10 2pcs	9 M4x30 3pcs
10 M6x45 8pcs	11 M6x45 4pcs	12 Ø12xØ5x0.8 3pcs
13 17x17x18 BLACK 4pcs		



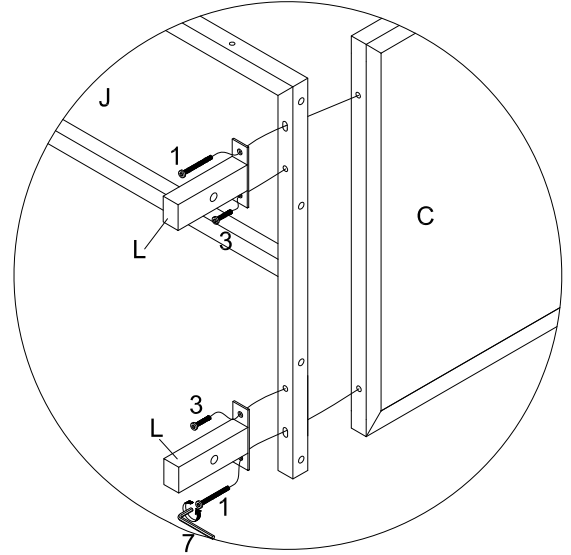
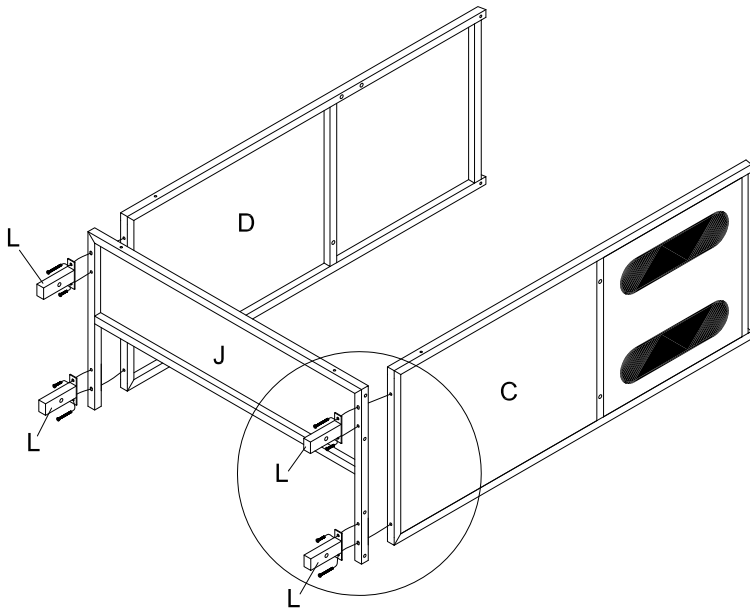



# STEP 1.

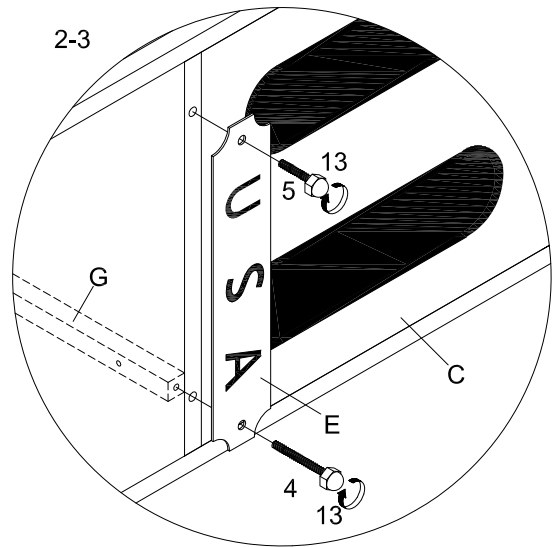
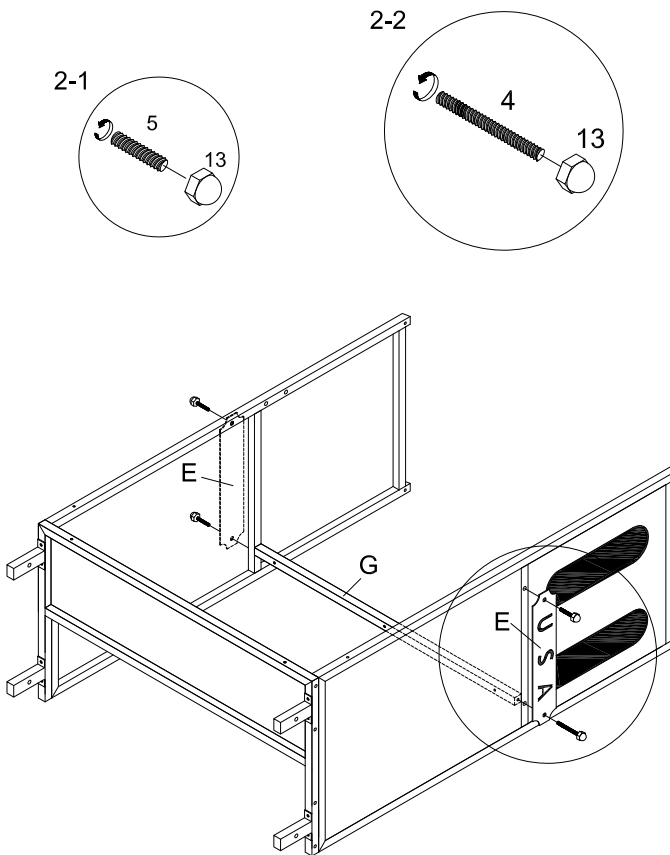

1		4pcs
M6x35		
3		4pcs
M6x15		

# STEP 2.



4		2pcs
M6x60		
5		2pcs
M6x25		
13		BLACK 4pcs
17x17x18		

# STEP 3.

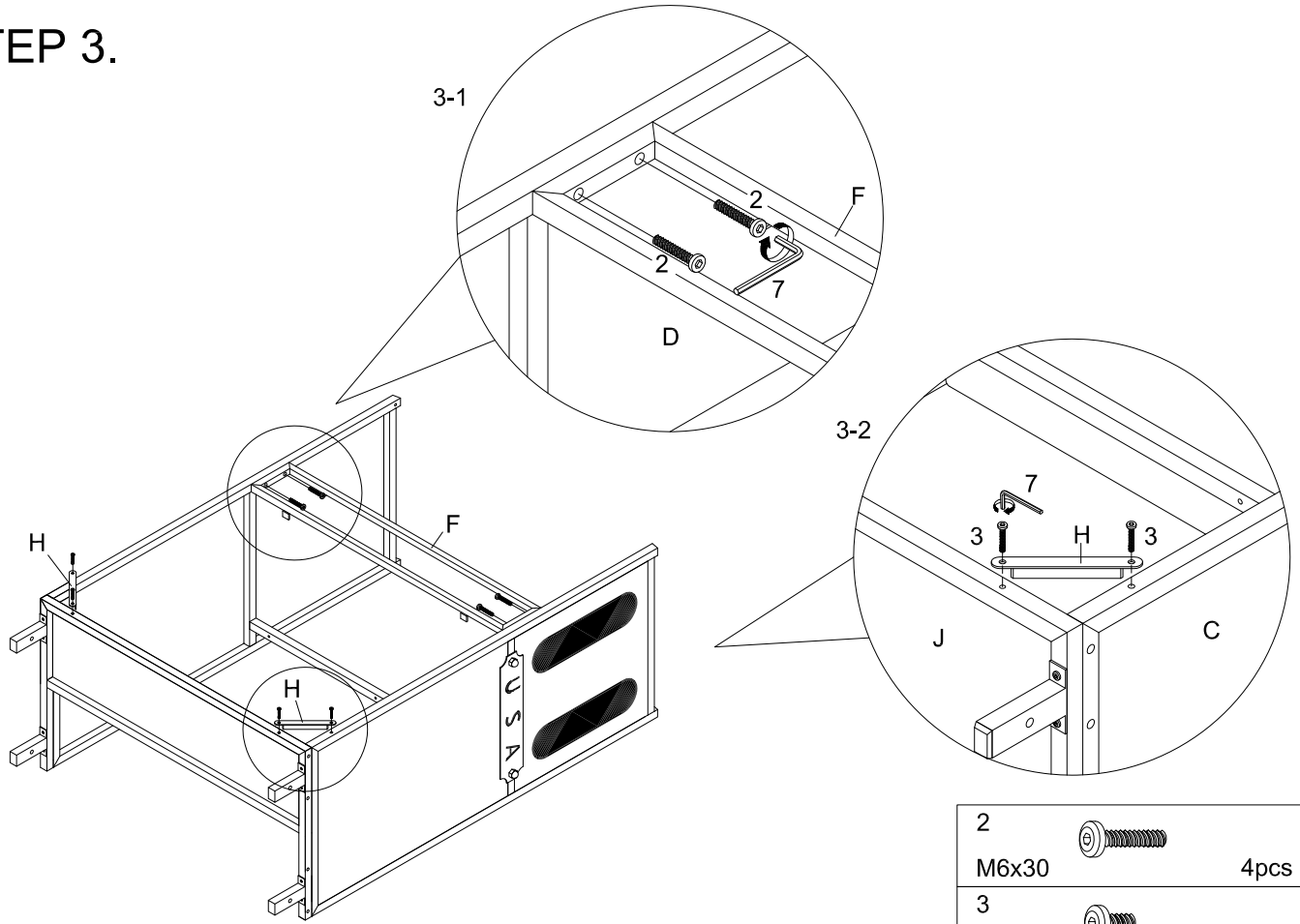

2		4pcs
M6x30		
3		4pcs
M6x15		

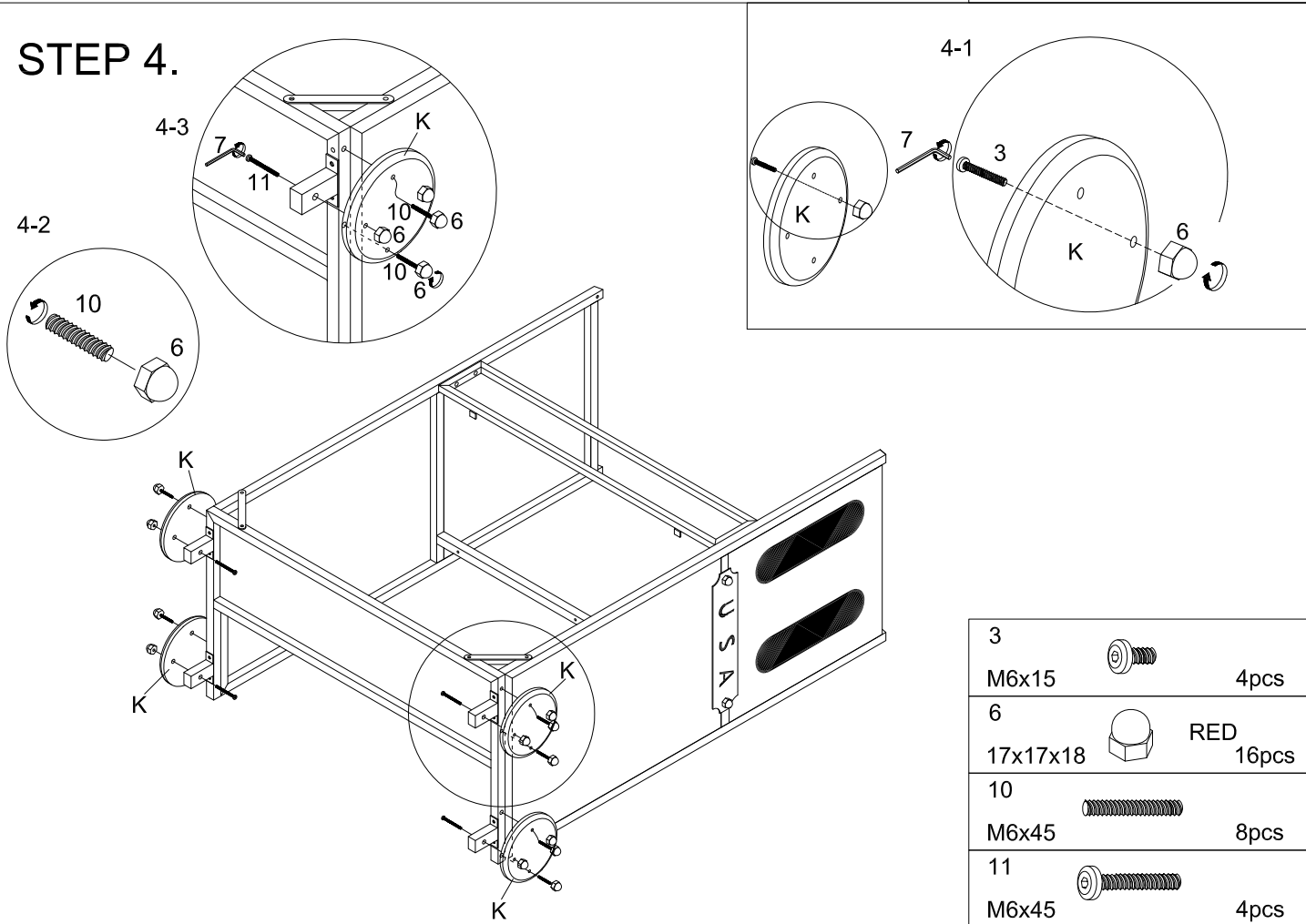

# STEP 4.



3		4pcs
M6x15		
6		16pcs
17x17x18	RED	
10		8pcs
M6x45		
11		4pcs
M6x45		

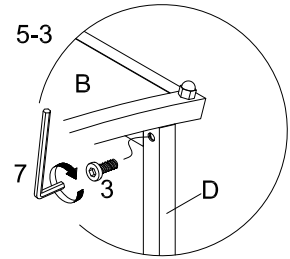
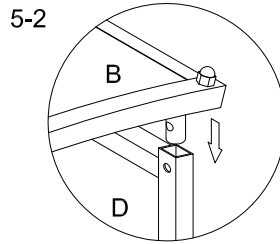
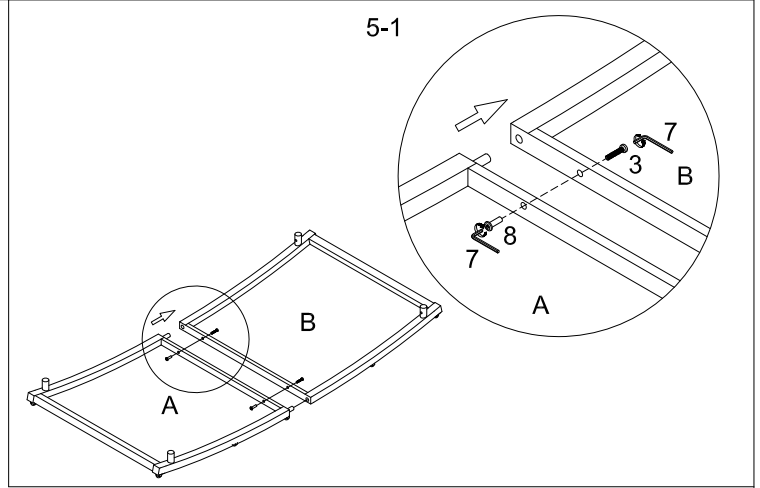
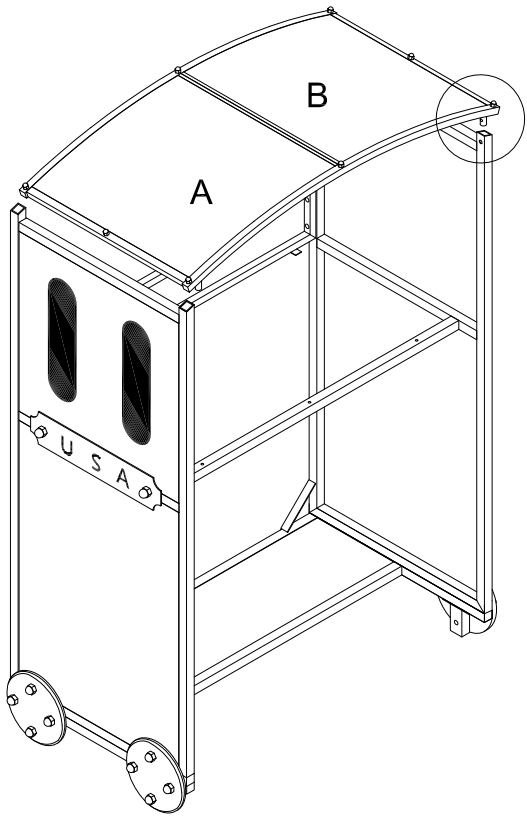

# STEP 5.

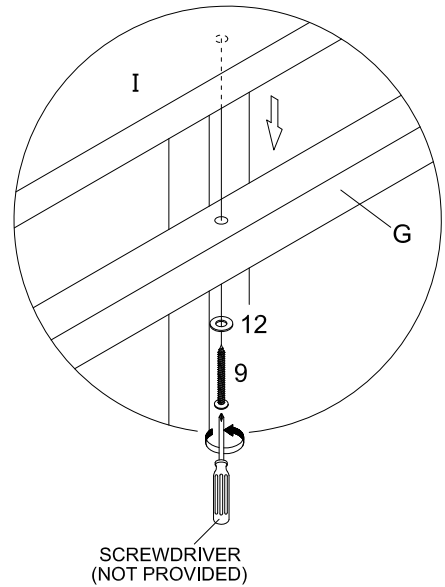
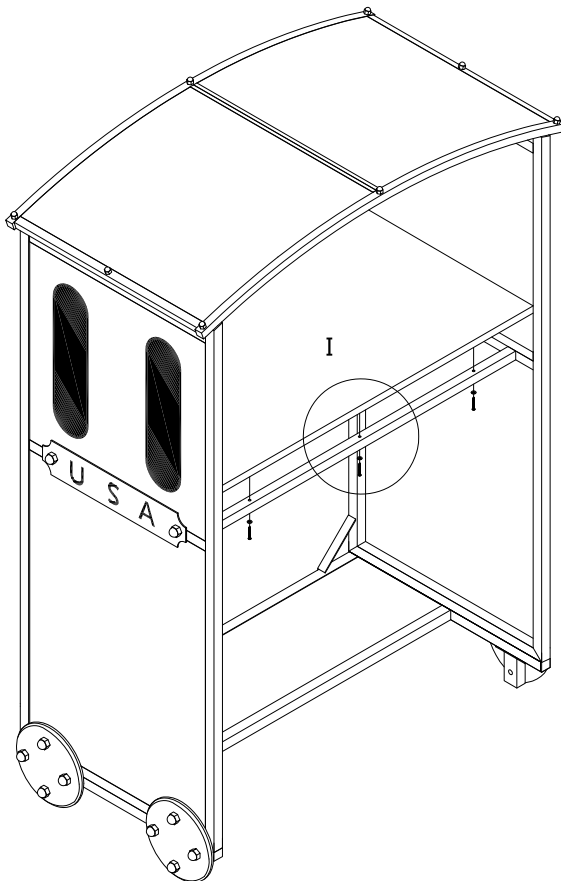

3		6pcs
M6x15		
8		2pcs
M6x10		

# STEP 6.



9		3pcs
M4x30		
12		3pcs
Ø12xØ5x0.8		