

**ACME  
FURNITURE**

## **ASSEMBLY INSTRUCTIONS**

**Item No: #36142 & 36143**





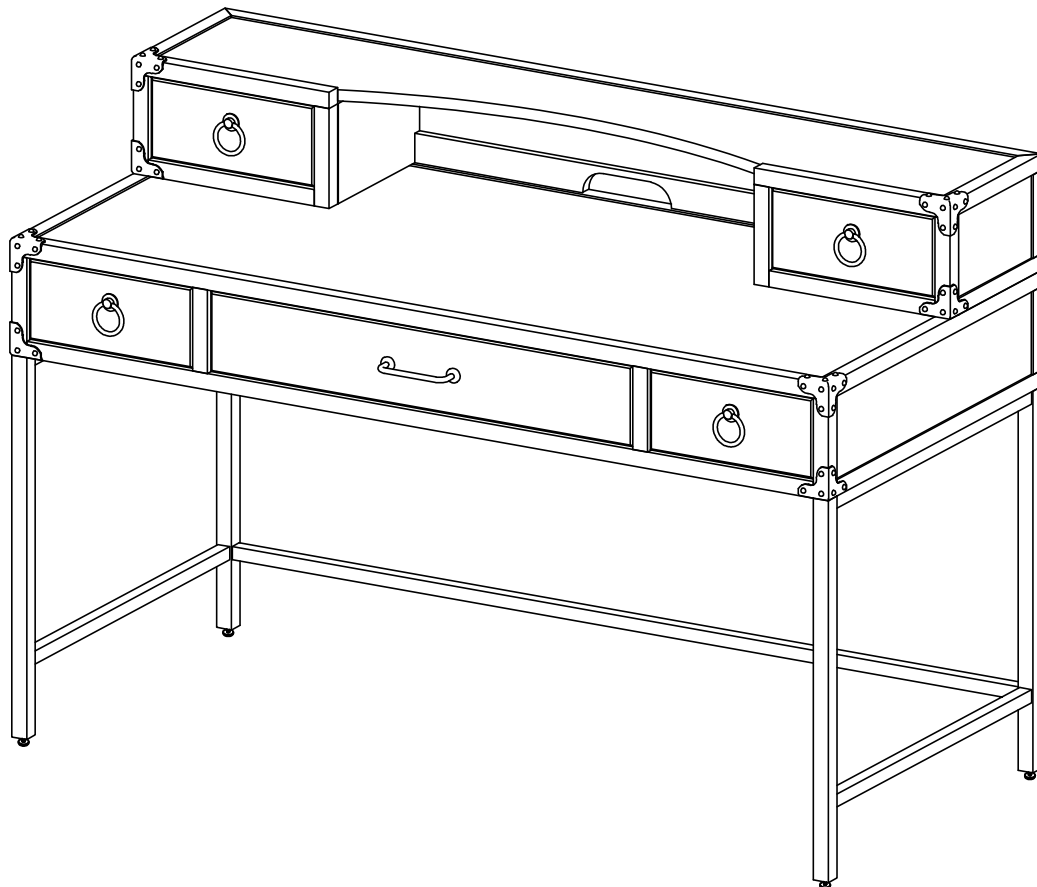

\*\*\* Thank you for purchasing this quality product. Be sure to check all packing materials carefully for small parts which may have come loose inside the carton during shipment. Identify and count all parts and compare with parts list below.

\*\*\* Assemble product on a flat, soft surface such as a carpet or cloth to prevent scratching the finish. Read all instruction and study the drawings carefully before starting the assembly process.







**IMPORTANT:** Do not tighten bolts completely until all bolts are completely lined up and inserted into holes

## PARTS LIST

NO.	DIAGRAM	PART NAME	Q'Ty
1		Front Leg Frame	1 pc
2		Back Leg Frame	1 pc
3		Upper Stretcher	2 pcs
4		Lower Stretcher	2 pcs
5		Computer Desk	1 pc
6		Upper Desk	1 pc

## HARDWARE LIST

NO.	DIAGRAM	PART NAME	Q'Ty
A		Bolt 6.3 x 15 (mm)	20 pcs
B		Screw: 4 x 40 (mm)	12 pcs
C		Screw: 4 x 20 (mm)	6 pcs
D		Allen Key (M4)	1 pc

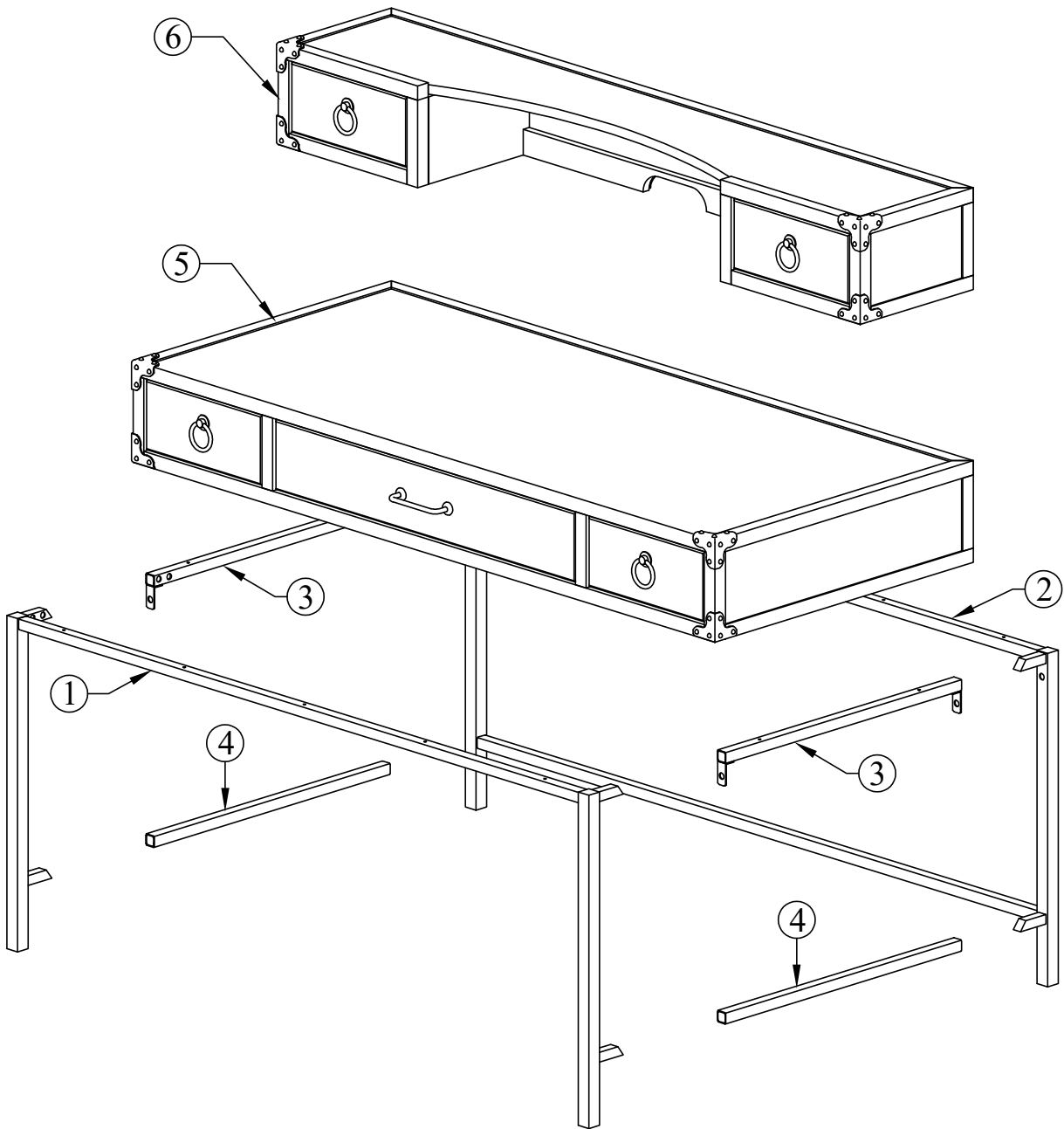

## STEP 1: LEG FRAME ASSEMBLY

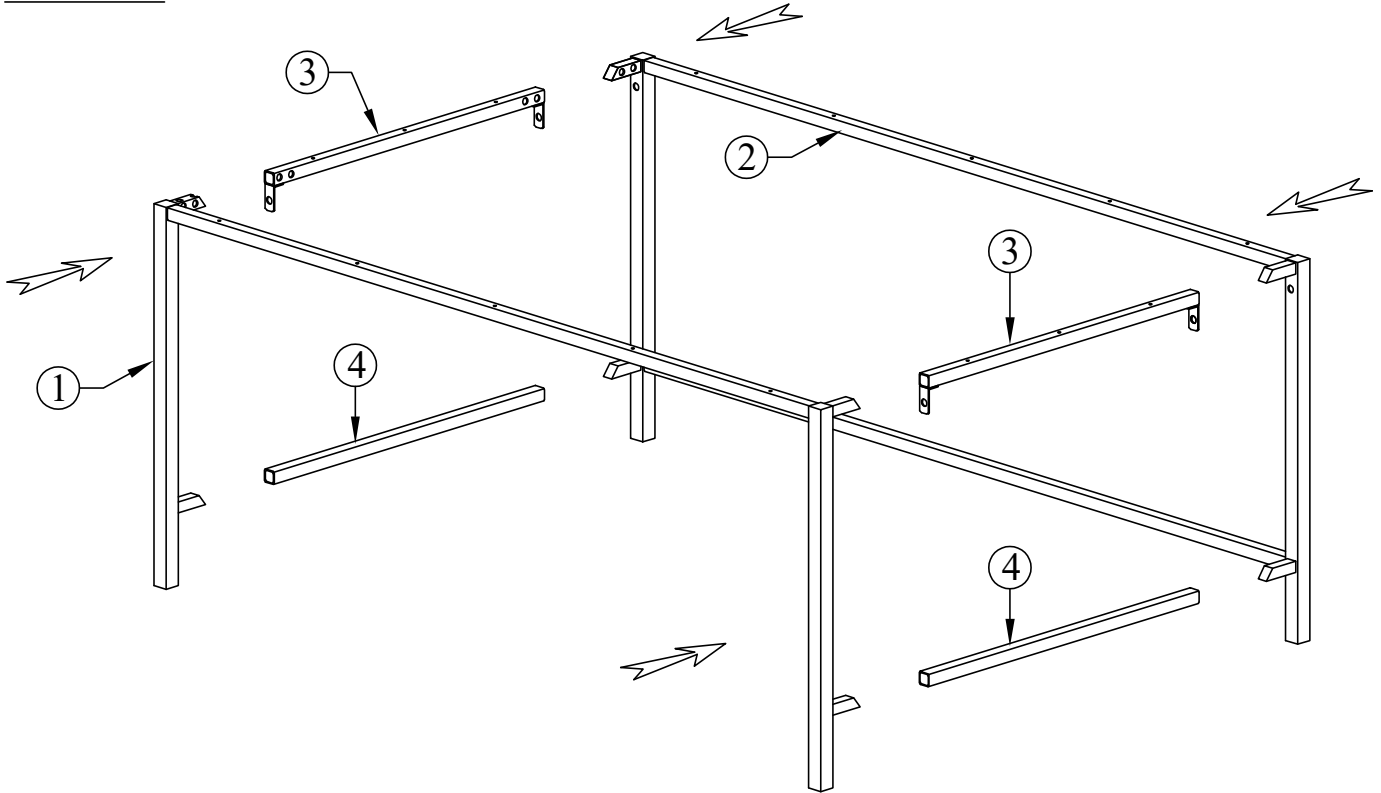

## STEP 2: LEG FRAME ASSEMBLY

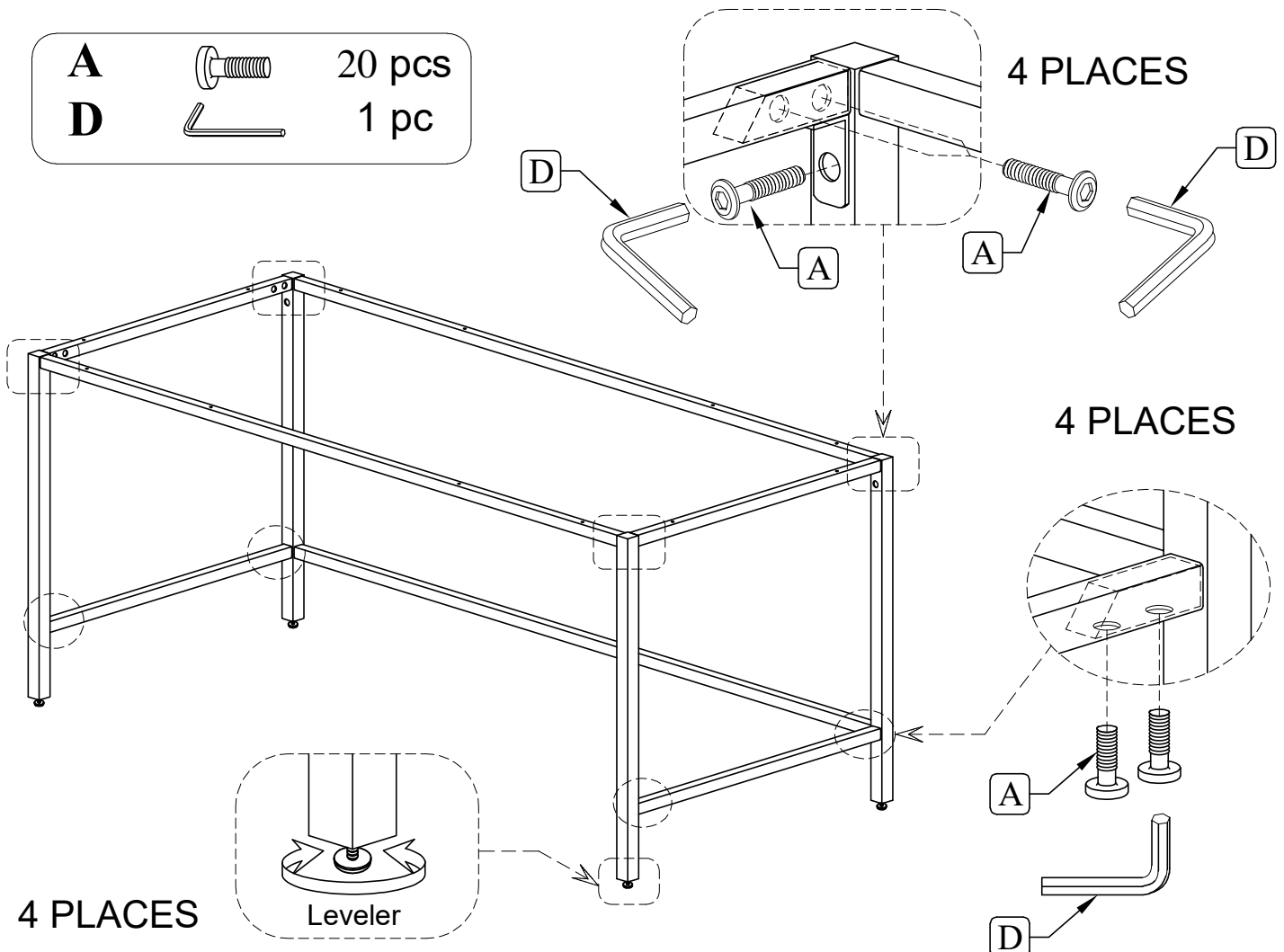

**STEP 3: LEG FRAME - COMPUTER DESK ASSEMBLY**

**B**



14 pcs

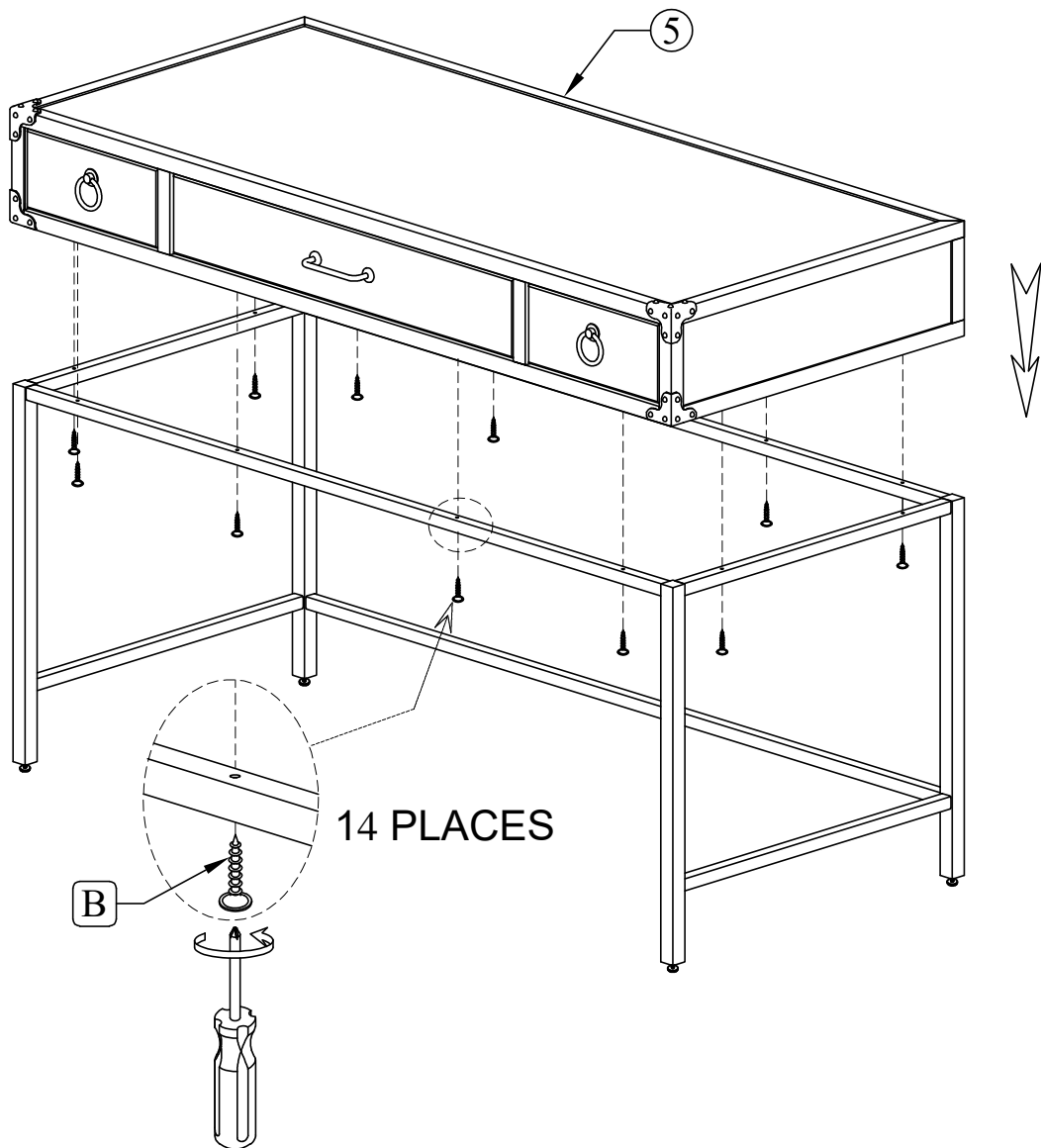

**STEP 4: LEG FRAME - COMPUTER DESK - UPPER DESK ASSEMBLY**

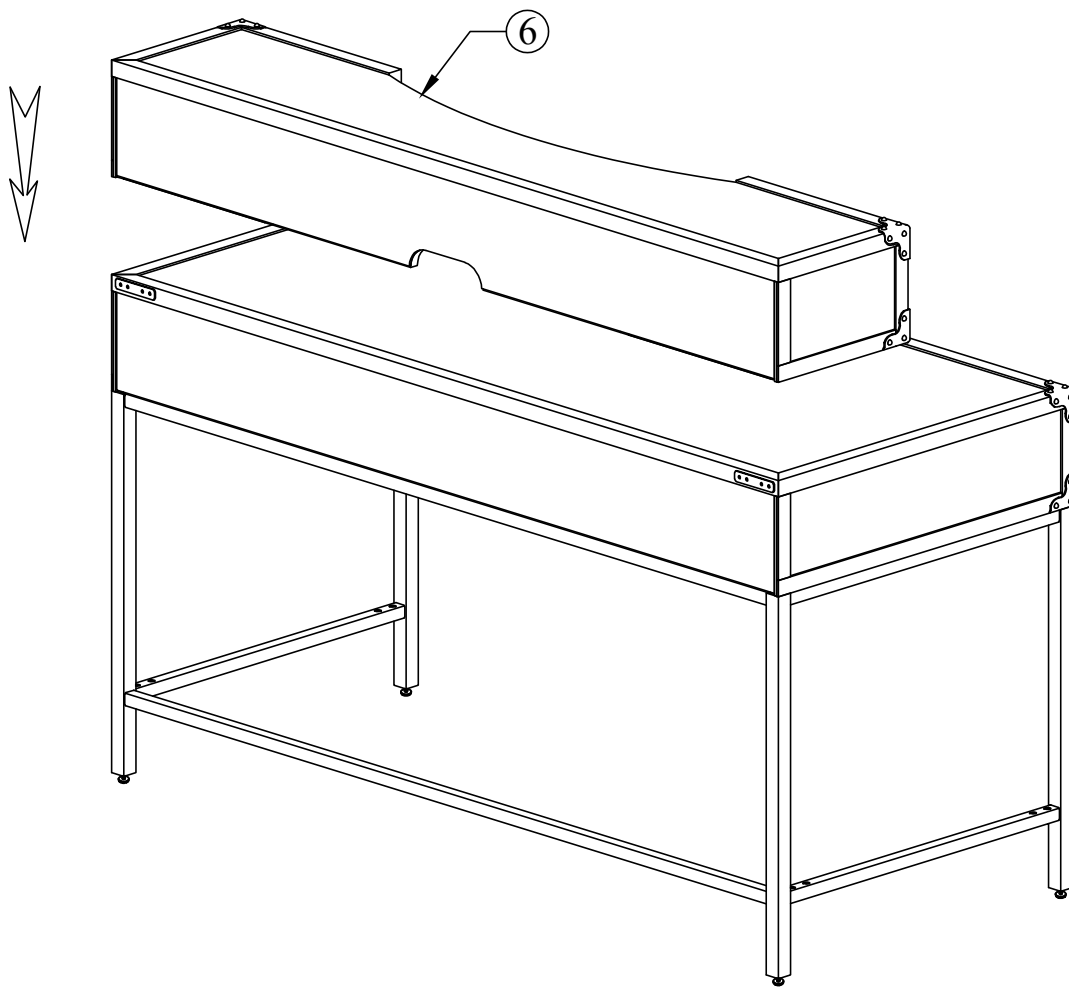

**STEP 5: LEG FRAME - COMPUTER DESK - UPPER DESK ASSEMBLY**

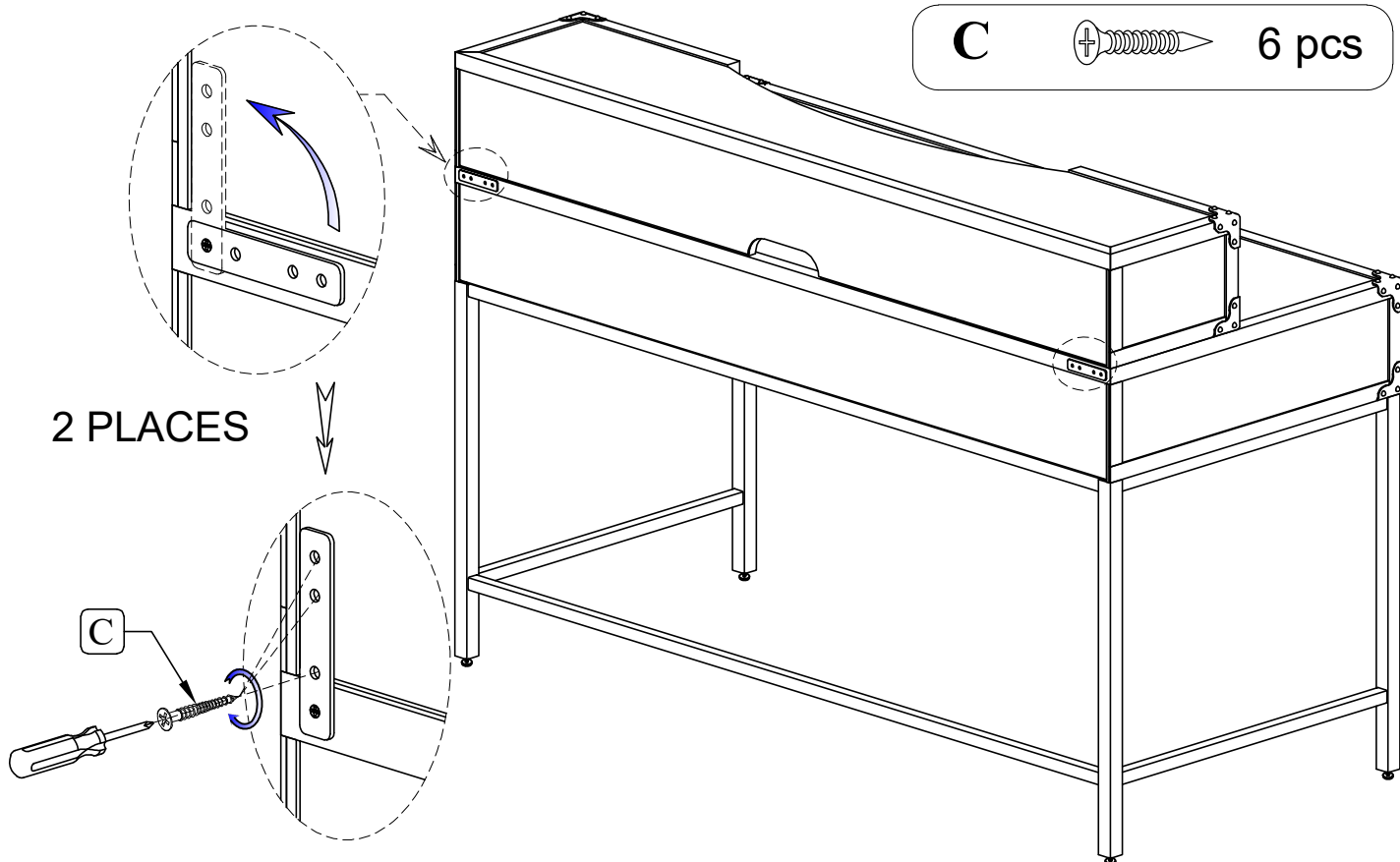

**STEP 6:**

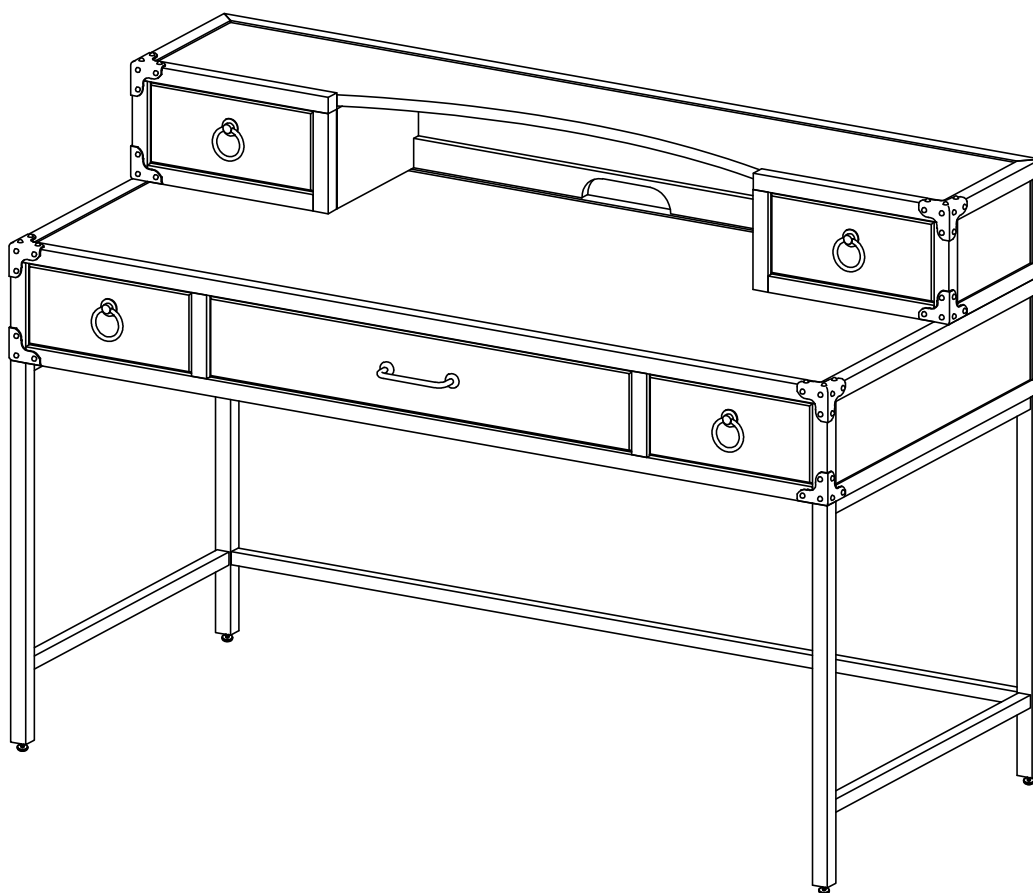

**ASSEMBLY IS COMPLETED**