











# ASSEMBLY INSTRUCTION ITEM NO: 20907EK











Thank you for purchasing this quality product. Be sure to check all packing material carefully for small parts which may have come loose inside the carton during shipment. Separate, identify and count all parts and hardware. Compare with the parts list to be sure all parts are present.

**"DO NOT TIGHTEN SCREWS UNTIL COMPLETELY ASSEMBLED"**

## IMPORTANT:

PLEASE READ INSTRUCTION BEFORE STARTING THE ASSEMBLY

| HARDWARE LIST |               |   |           |       |
|---------------|---------------|---|-----------|-------|
| ITEM          | DESCRIPTION   | DRAWING   | SIZE      | QTY   |
| A             | JCBB SCREW    |    | M8 X 20MM | 8PCS  |
| B             | JCBC SCREW    |    | M6 X 25MM | 8PCS  |
| C             | JCBC SCREW    |    | M6 X 35MM | 14PCS |
| D             | JCBC SCREW    |    | M6 X 70MM | 2PCS  |
| E             | WOOD DOWEL    |   | M8 X 30MM | 2PCS  |
| F             | SPRING WASHER |  | M6 x 13MM | 14PCS |
| G             | FLAT WASHER   |  | M6 x 19MM | 14PCS |
| H             | SCREW         |  | M4 X 32MM | 8PCS  |
| I             | L - KEY       |  | M5 X 65MM | 1PC   |
| J             | L - KEY       |  | M4 X 65MM | 1PC   |

| PART LIST |                                   |   |      |
|-----------|-----------------------------------|---|------|
| ITEM      | DESCRIPTION                       | DRAWING   | QTY  |
| 1         | HEADBOARD CUSHION                 |    | 1PC  |
| 2         | HEADBOARD LEG (R)                 |    | 1PC  |
| 3         | HEADBOARD LEG (L)                 |    | 1PC  |
| 4         | FOOTBOARD CUSHION                 |   | 1PC  |
| 5         | FOOTBOARD LEG                     |  | 2PCS |
| 6         | SIDE RAIL                         |  | 2PCS |
| 7         | SIDE RAIL                         |  | 2PCS |
| 8         | SIDE RAIL SUPPORT LEG             |  | 2PCS |
| 9         | SLAT                              |  | 4PCS |
| 10        | SUPPORT LEGS WITH ADJUSTABLE FEET |  | 8PCS |

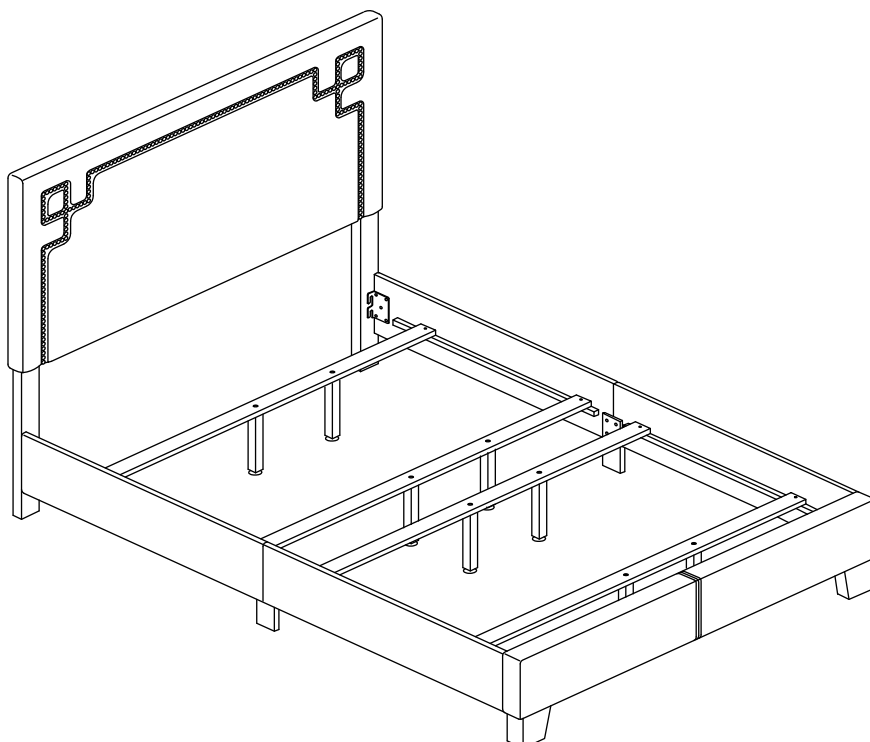

# ASSEMBLY INSTRUCTION

ITEM NO : 20907EK

STEP 1

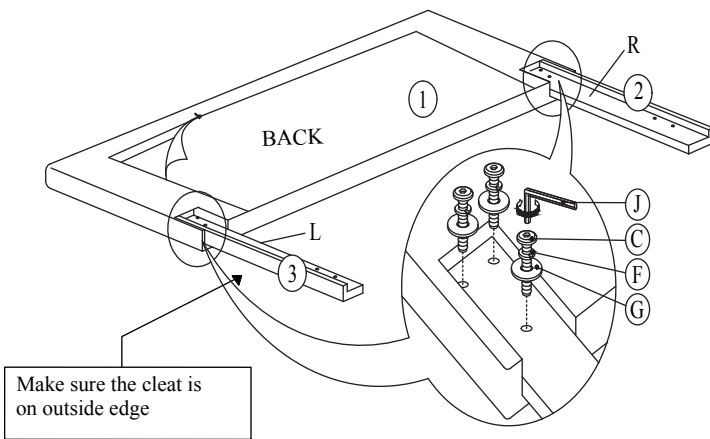

STEP 2

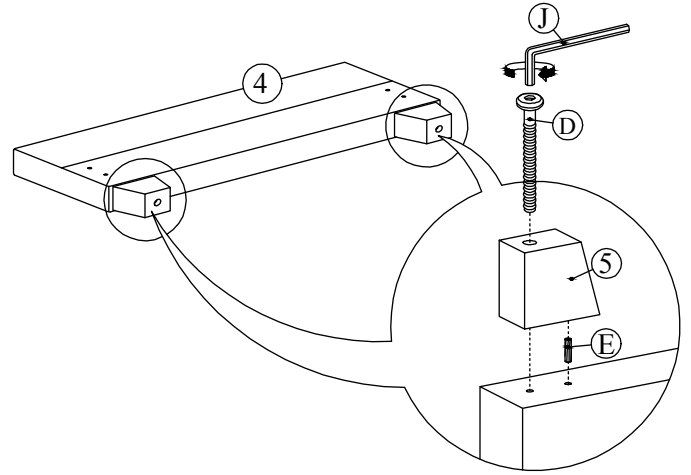

STEP 3

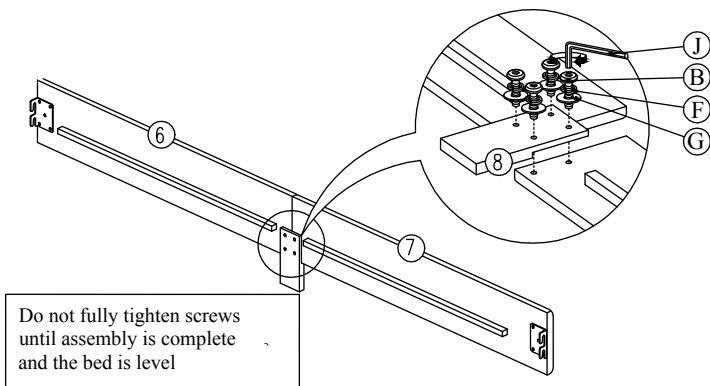

STEP 4

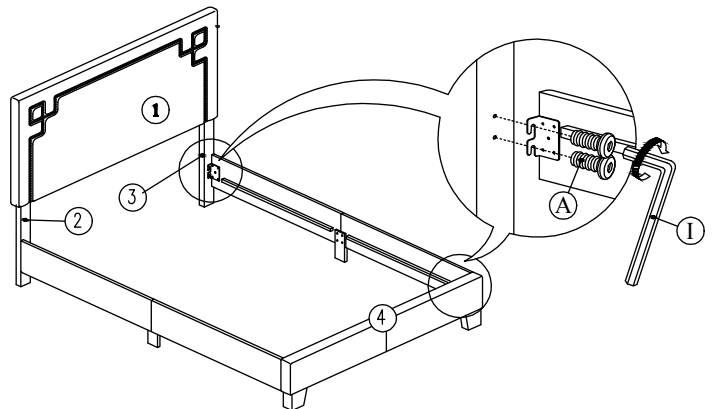

STEP 5

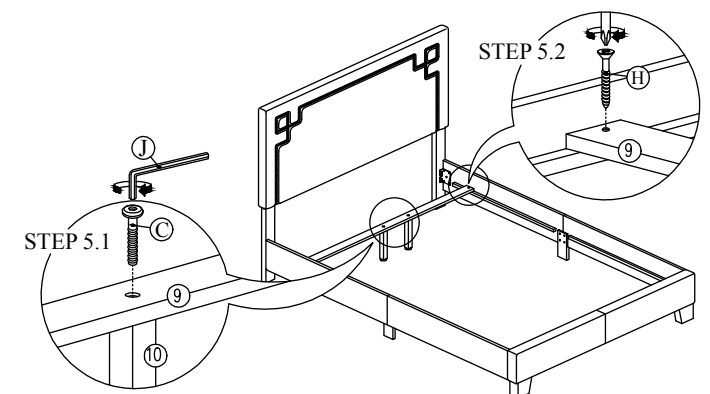

STEP 6

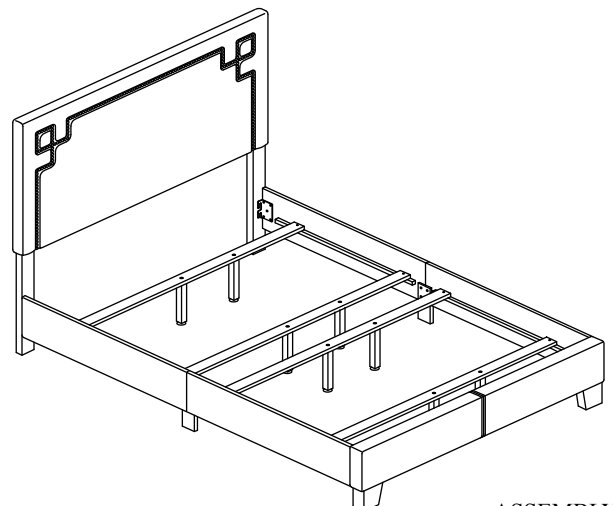

ASSEMBLY  
COMPLETED