

ASSEMBLY INSTRUCTION

Step 1:

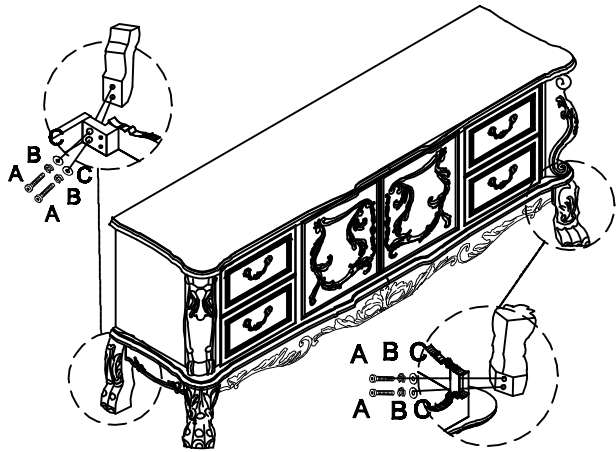

Step 2:

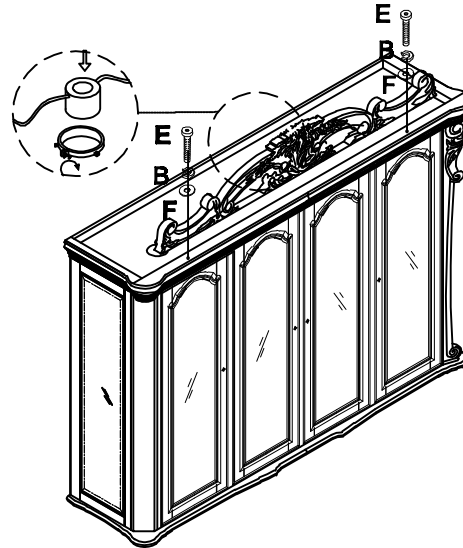

Step 3:

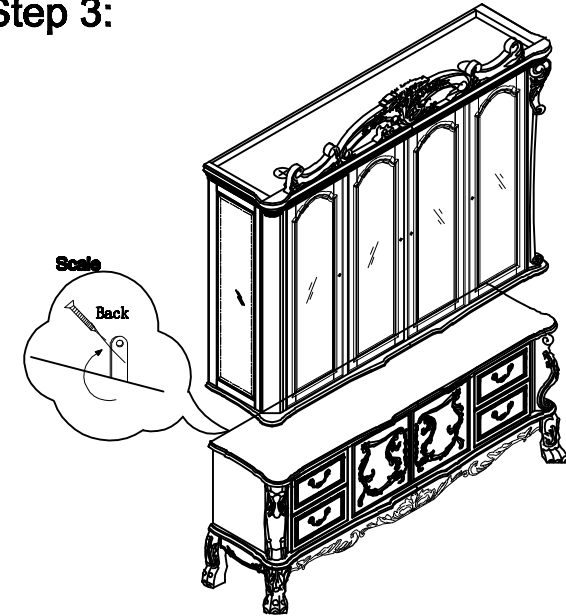

Step 4:

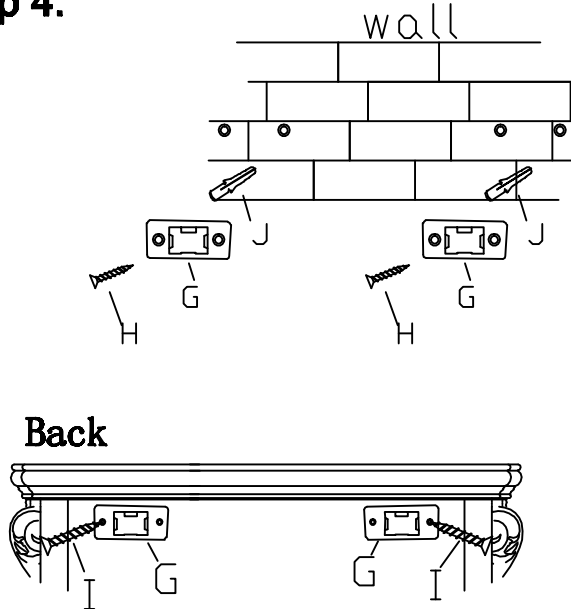

Step 5:

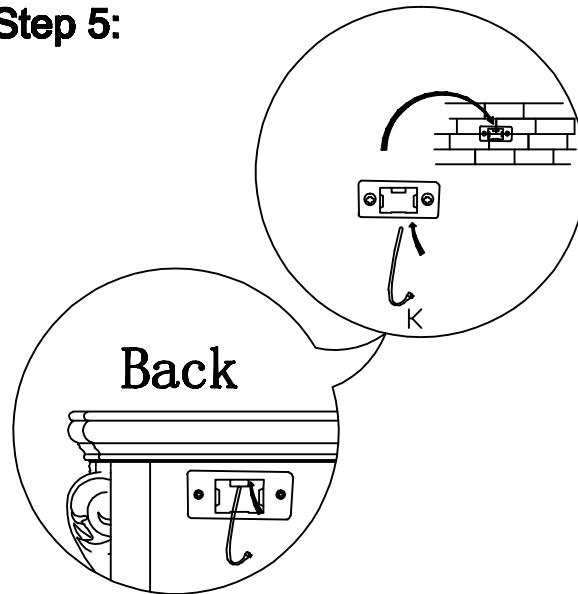

Finish :

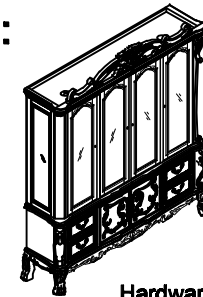

Hardware List

No.:	Description	Drawing	Size	Q'ty
A	Bolt		Ø5/16"X2-1/4"	8
B	Lock Washer		Ø1/8"	10
C	Flat Washer		Ø1/8"X22mm	8
D	Allen Wrench		5mm	1
E	Bolt		Ø5/16"X2"	2
F	Flat Washer		Ø5/16"X19mm	2
G	Fasten unit		44mmX20mm	4
H	Long Screw		Ø7mmX38mm	4
I	Shrink Screw		Ø6mmX16mm	4
J	Shrink bolt		Ø5/16"X1-1/2"	4
K	Selfy bolt		ØmmX250mm	2